

DO NOT SCALE

IF IN DOUBT, ASK!

REVISIONS		
REV.	DESCRIPTION	DATE
0	FIRST ISSUE	10/11/22

A
B
C
D
E
F
G
H

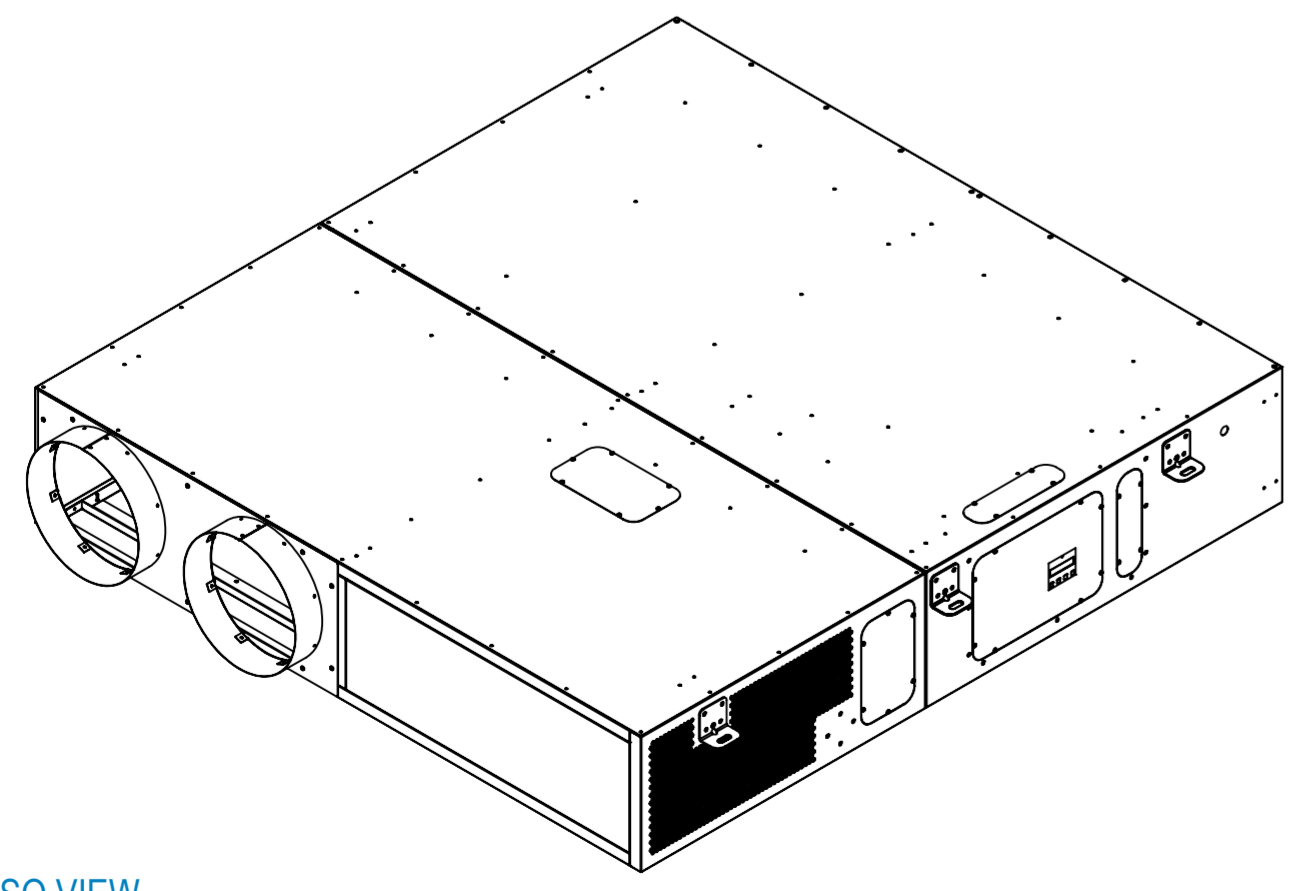
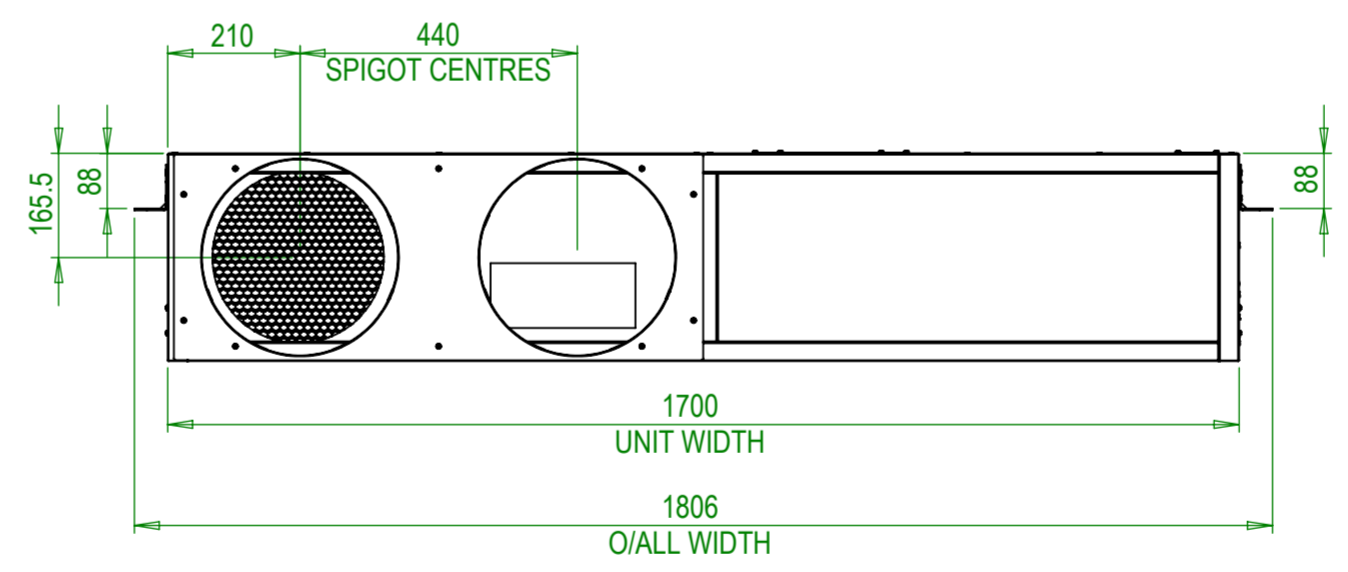
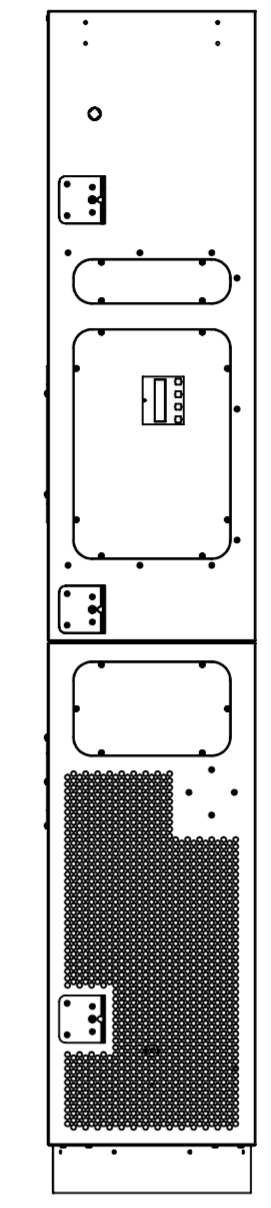
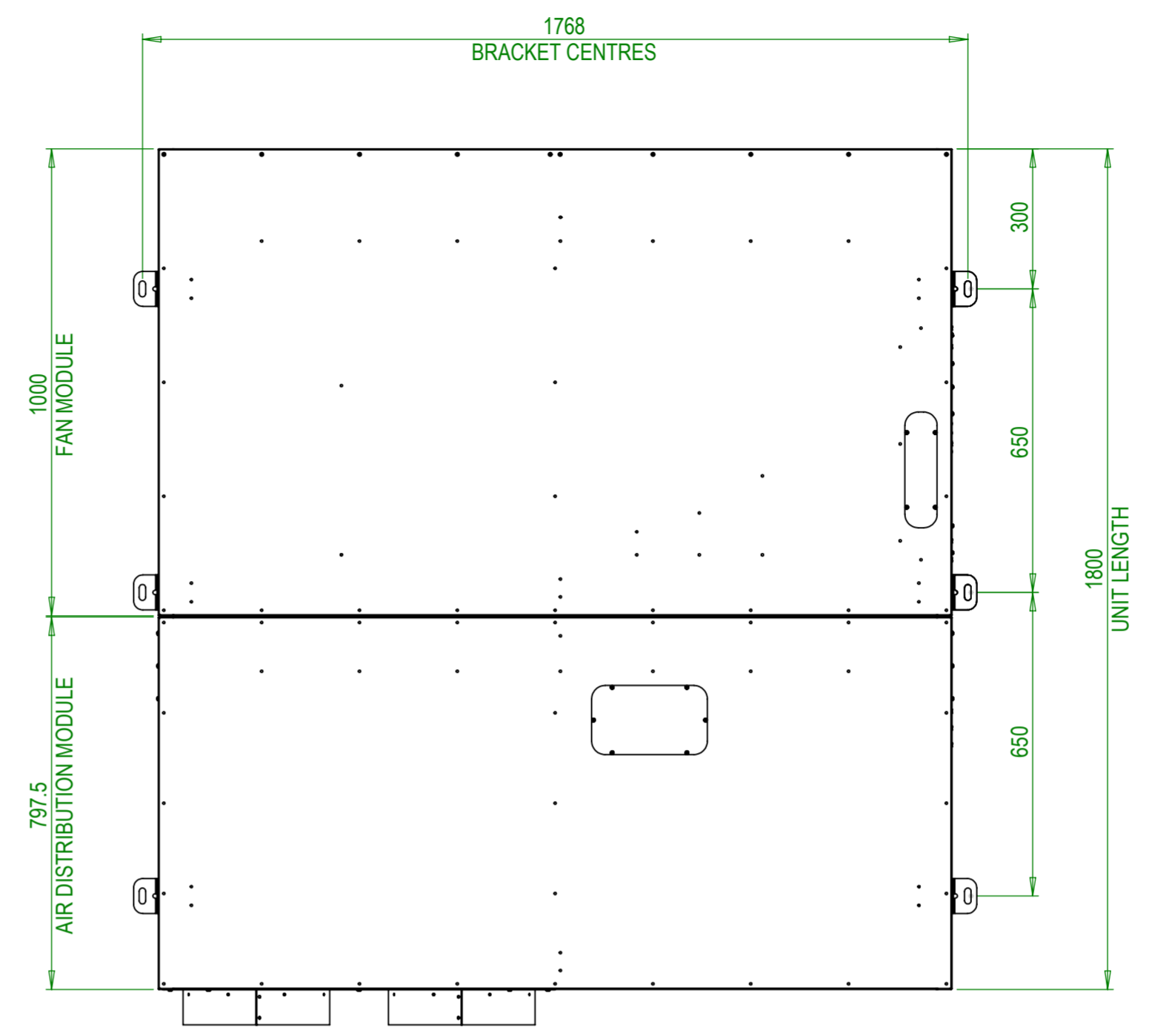
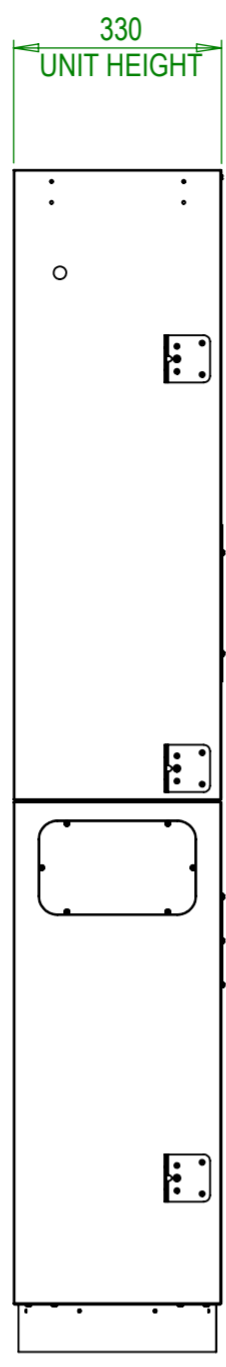
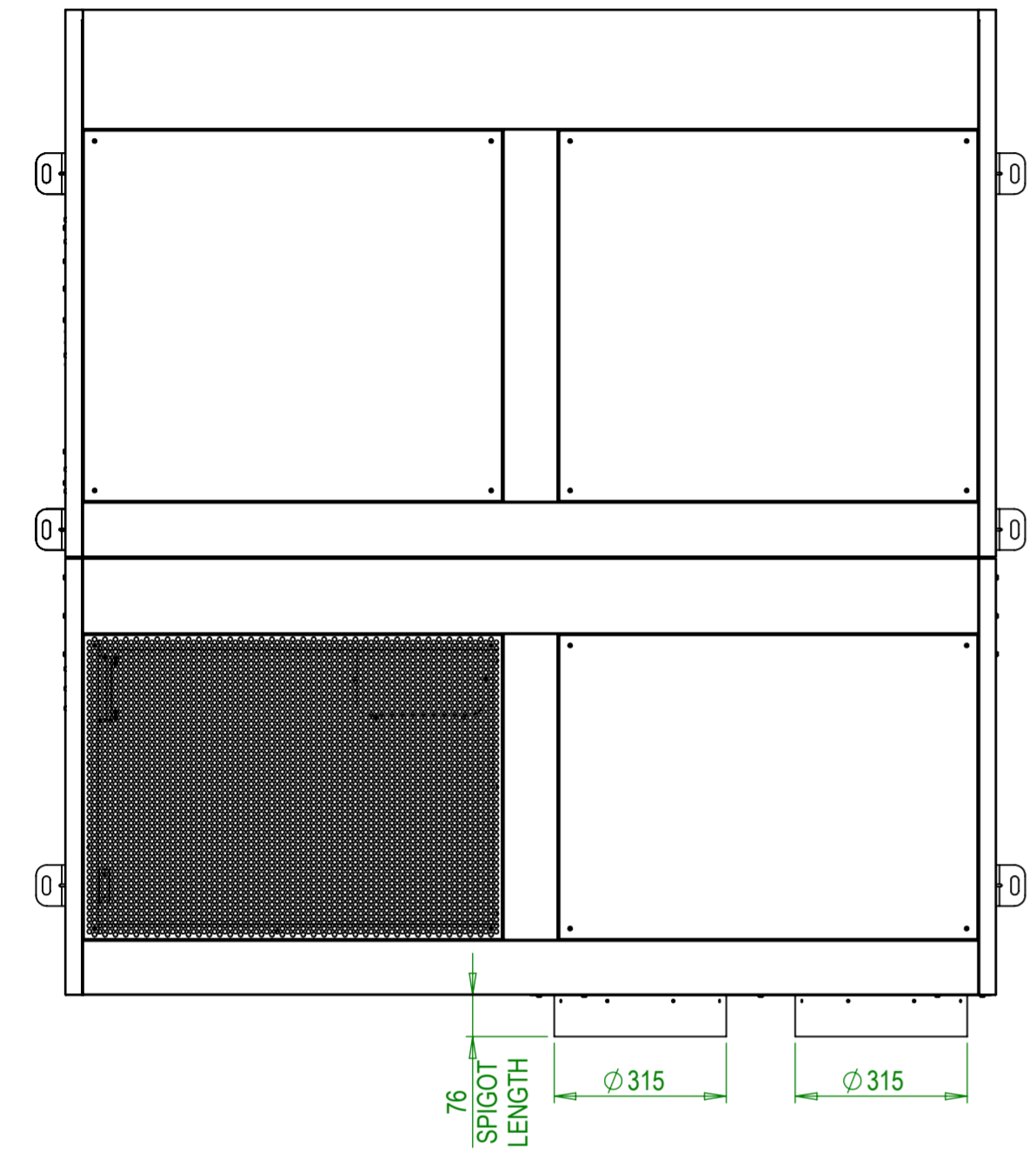

ISO VIEW
1:15

MATERIAL:
GALVANIZED STEEL

FINISH
POWDER COATED RAL 9003 SIGNAL WHITE

MASS WITHOUT PACKAGING
130kg

TOLERANCES EXCEPT WHERE OTHERWISE STATED

SIZE (mm)	X XX	TOLERANCE
over 0.5	up to 6	±0.1
over 6	up to 100	±0.2
over 100	up to 500	±0.5
over 500	up to 1000	±0.8
over 1000		±1.2

DE-BURR ALL SHARP EDGES AND HOLES
ITEM MUST BE FREE FROM SCRATCHES, DENTS AND
OTHER BLEMISHES.

DIMENSIONS IN MILLIMETRES



TITLE:
NVHR 1700 SPIGOT -
DIMENSIONED DRAWING

DRAWING NO:
2201_9000

REV	DRAWN	DATE	CHK'D	DATE
0	MJW	10/11/2022	Not chkd	N/A

SCALE 1:12 A2 SHEET 1 OF 1



BREATHING BUILDINGS CONTINUOUSLY WORK TO IMPROVE OUR PRODUCTS. TO ENSURE UP TO DATE DRAWINGS, PLEASE CONTACT BREATHING BUILDINGS.