

DO NOT SCALE

IF IN DOUBT, ASK!

REVISIONS

REV.	DESCRIPTION	DATE	DRAWN
1	FIRST ISSUE	27/10/2014	CC
2	MINOR UPDATE	29/09/2015	CC
3	ADDED WEIGHT	11/08/2016	CC

NOTES:

1. UNIT FINISHED IN GALVANISED AS STANDARD. RAL COLOURS AVAILABLE ON REQUEST AT ADDITIONAL COST.
2. MIXED AIR DELIVERY SUPPLY THROUGH SIDE "B" AS DEFAULT (SEE DIAGRAM "A" FOR HANDING'S). TO BE CONFIRMED BY CUSTOMER AT ORDER STAGE.
3. UNIT SUPPLIED WITH 4 NO. MOUNTING BRACKETS. UNIT SHOWN WITHOUT GRILLES. GRILLES AVAILABLE ON REQUEST AT ADDITIONAL COST.
4. IF UNIT IS POSITIONED LESS THAN 2.7m ABOVE GROUND, "FINGER GUARD" GRILLES MUST BE SPECIFIED.
5. WEIGHT APPROX. 40KG (EXCLUDING PALLET AND GRILLES).
6. ACCESS MUST BE PROVIDED TO CONTROL BOX, MINIMUM 600X600 ACCESS HATCH.

MATERIAL:
MILD STEEL

FINISH
GALV. OR ZINTEC POWDER COATED

MASS WITHOUT PACKAGING
75KG

TOLERANCES EXCEPT WHERE OTHERWISE STATED

X	±	0.5MM
X XX	±	0.05MM
ANGLES	±	0.5°

SURFACE TEXTURE TO BE 1.6 UMRA OR BETTER

DE-BURR ALL SHARP EDGES AND HOLES
ITEM MUST BE FREE FROM SCRATCHES, DENTS AND OTHER BLEMISHES.

DIMENSIONS IN MILLIMETRES



UNIT 3A, THE SHADE, SOHAM, CB7 5HF
T: 01223 450060 F: 01223 450061
www.breathingbuildings.com/products

TITLE:

E-STACK: F1000 (WITHOUT INTEGRAL DAMPER) VERSION 1

DRAWING NO:

1410_9001

REV	DRAWN	DATE	CHK'D	DATE
3	CC	11/08/2016		

SCALE 1:20 A3 SHEET 1 OF 2

PLAN VIEW

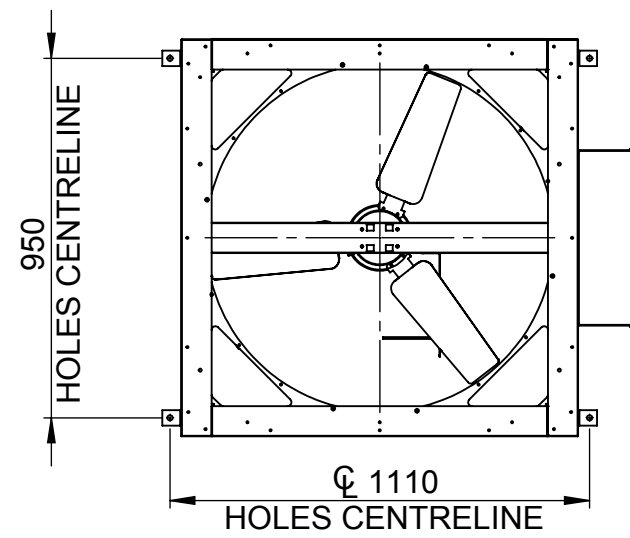

REVERSE ISOMETRIC

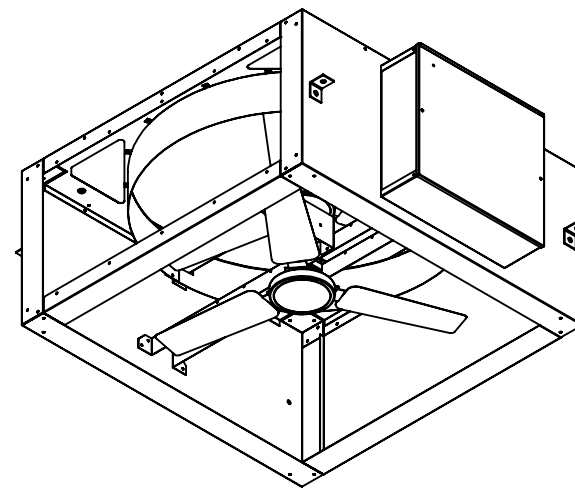

ISOMETRIC

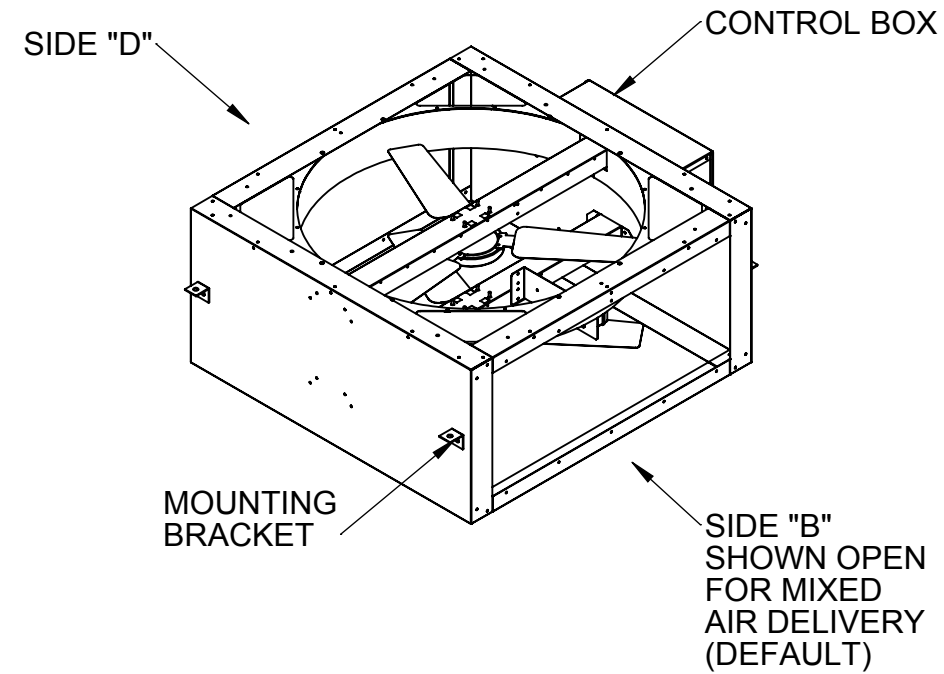

A

B

C

D

E

F

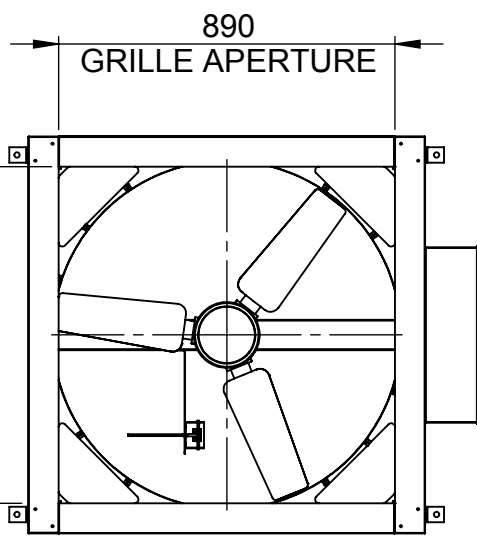
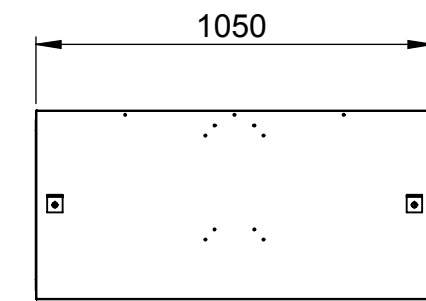
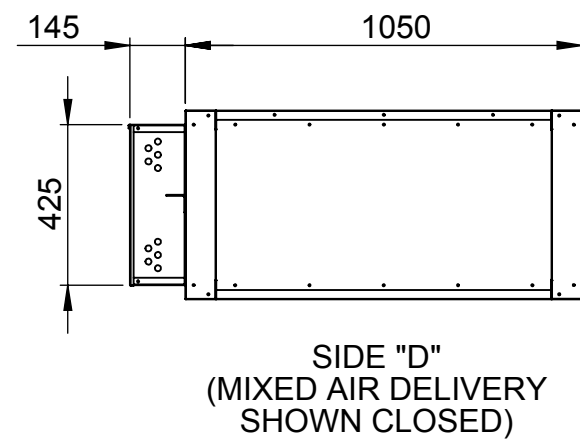
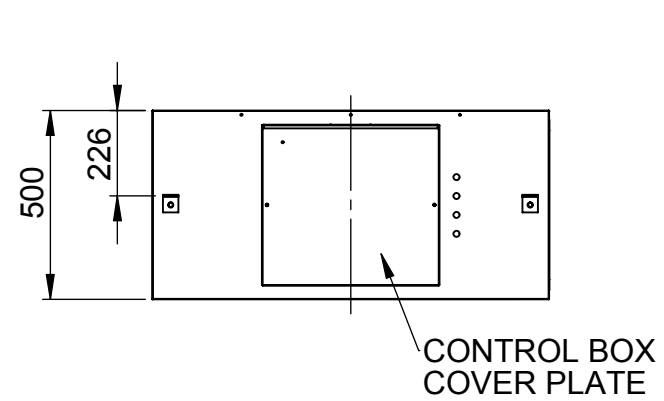
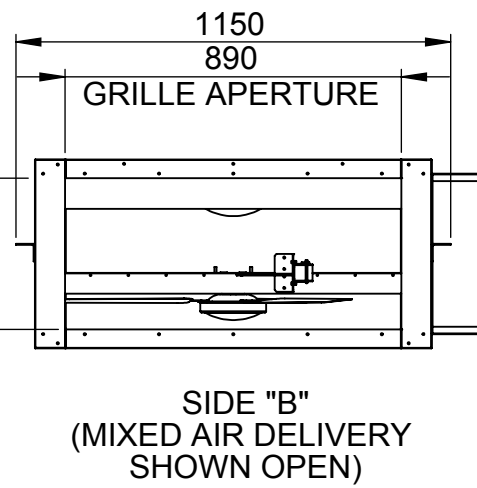

UNDERSIDE VIEW

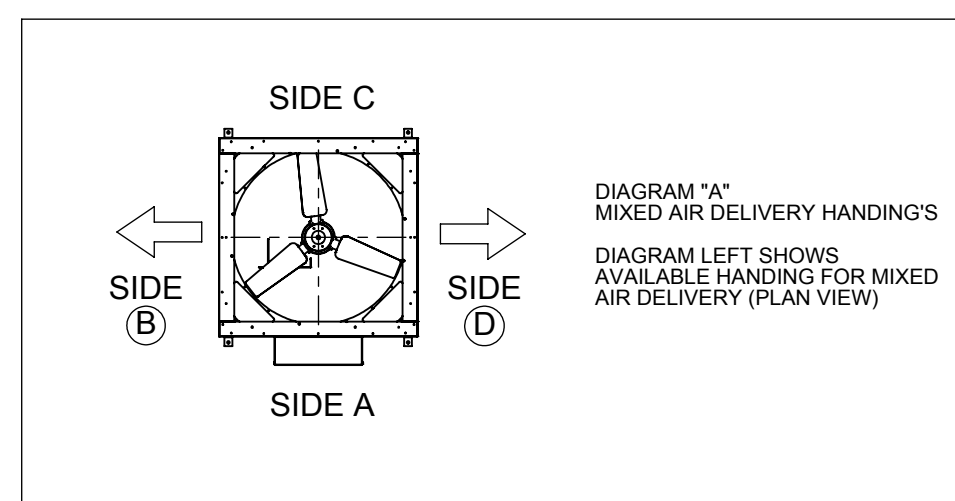

BREATHING BUILDINGS CONTINUOUSLY WORK TO IMPROVE OUR PRODUCTS. TO ENSURE UP TO DATE DRAWINGS, PLEASE CONTACT BREATHING BUILDINGS.

DO NOT SCALE

IF IN DOUBT, ASK!

REVISIONS

REV.	DESCRIPTION	DATE	APPROVED
-	See Sheet1	-	-

SIDE
(SHOWN WITH EGG CRATE GRILLE)

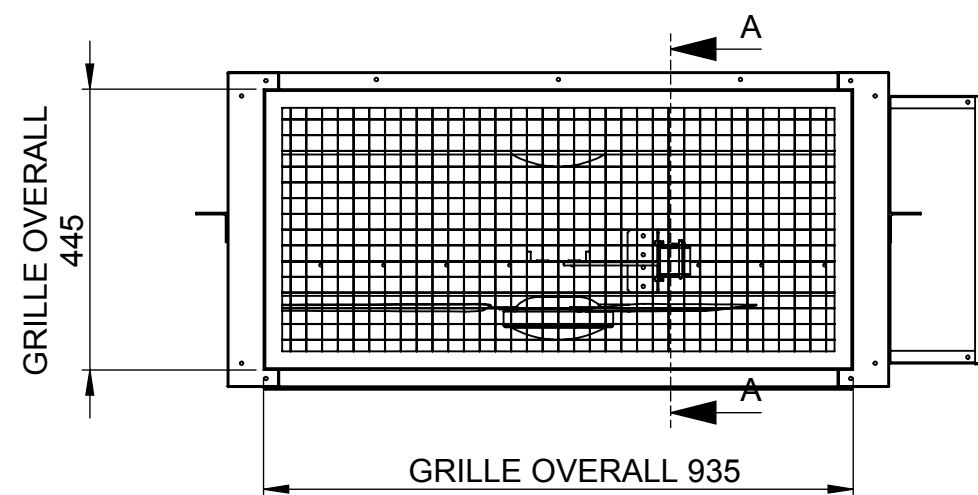

SECTION A-A

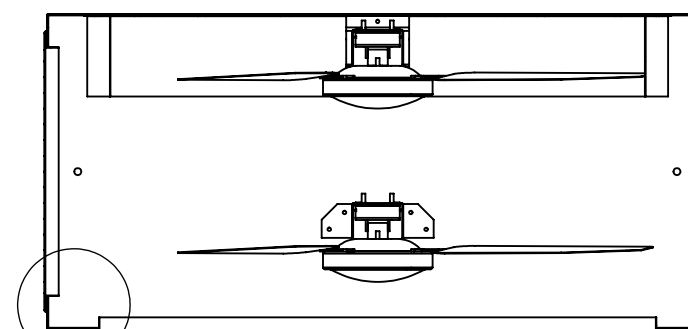

UNDERSIDE
(SHOWN WITH EGG CRATE GRILLE)

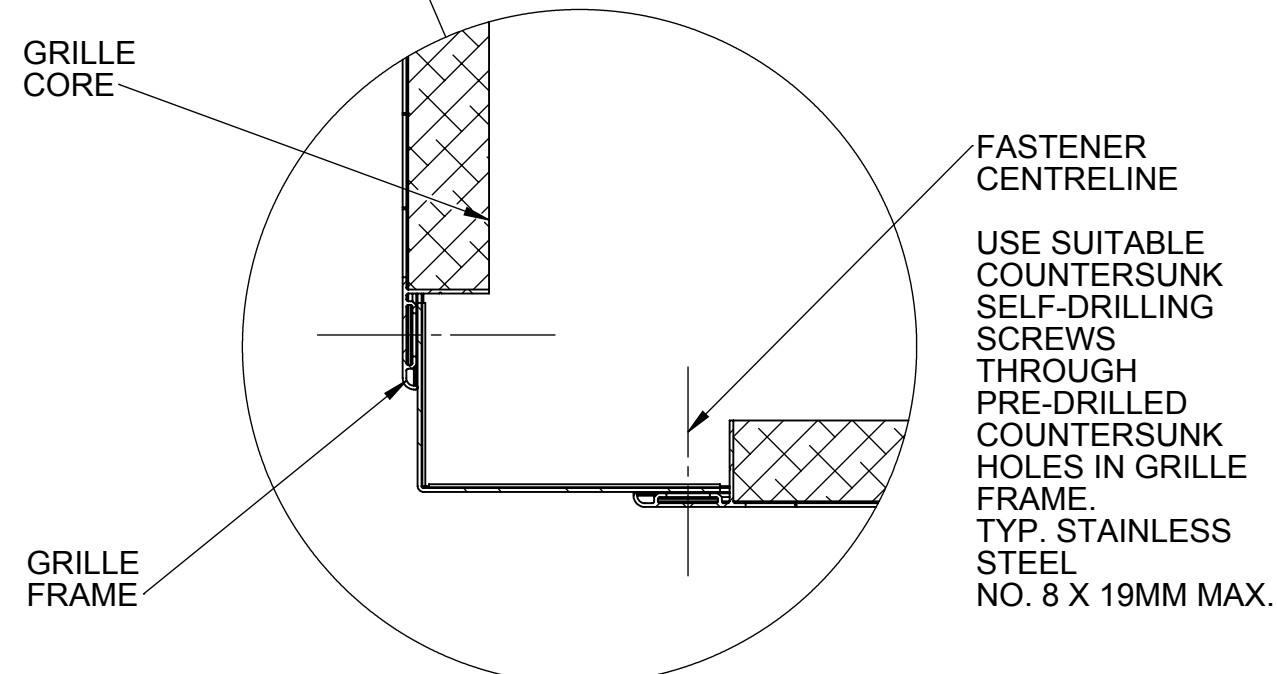
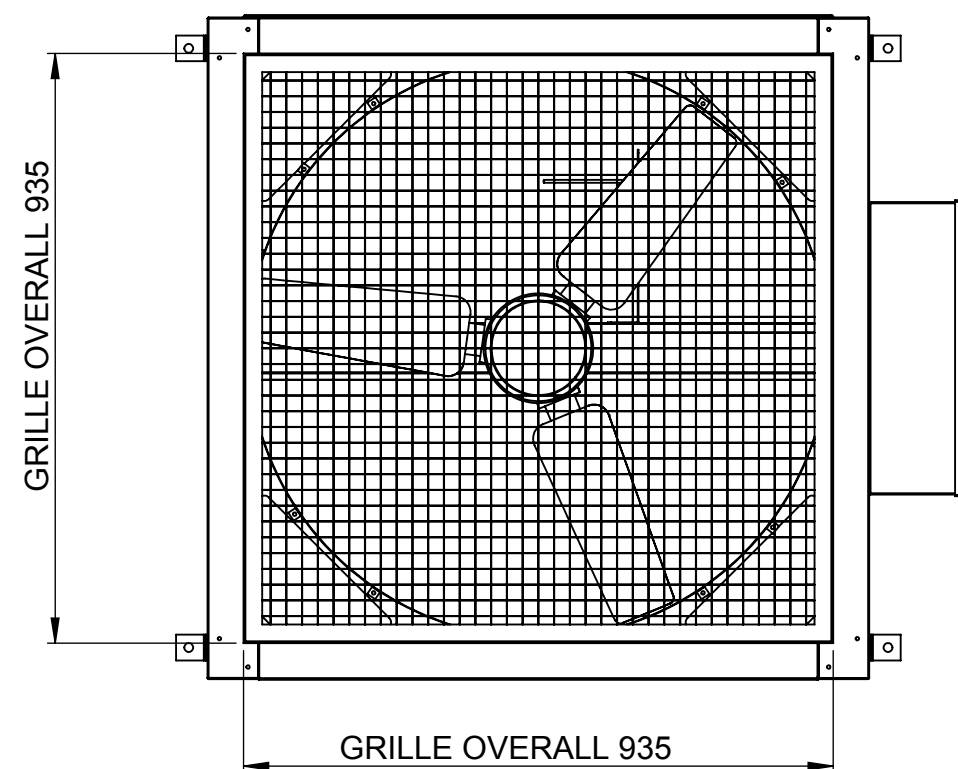

DETAIL A
SCALE 1 : 2
GRILLE FIXINGS

MATERIAL:
MILD STEEL

FINISH
GALV. OR ZINTEC POWDER COATED

MASS WITHOUT PACKAGING
75KG

TOLERANCES EXCEPT WHERE OTHERWISE STATED

X	±	0.5MM
X.XX	±	0.05MM
ANGLES	±	0.5°

SURFACE TEXTURE TO BE 1.6 UMRA OR BETTER

DE-BURR ALL SHARP EDGES AND HOLES
ITEM MUST BE FREE FROM SCRATCHES, DENTS AND
OTHER BLEMISHES.

DIMENSIONS IN MILLIMETRES



UNIT 3A, THE SHADE, SOHAM, CB7 5HF
T: 01223 450060 F: 01223 450061
www.breathingbuildings.com/products

TITLE:

DRAWING NO:
1410_9001

REV	DRAWN	DATE	CHK'D	DATE
3	CC	11/08/2016		

SCALE 1:12 A3 SHEET 2 OF 2

GRILLE DIMENSIONS		
LOCATION	QTY (PER UNIT)	APERTURE
SIDE	1	890X400
UNDERSIDE	1	890X890

HEIGHT FROM FINISHED FLOOR LEVEL TO UNDERSIDE OF E-STACK	TYPE	OPEN AREA
>2.7M	EGG CRATE	12MM
<2.7M	FINGER GUARD	<8MM



BREATHING BUILDINGS CONTINUOUSLY WORK TO IMPROVE OUR PRODUCTS. TO ENSURE UP TO DATE DRAWINGS, PLEASE CONTACT BREATHING BUILDINGS.