

**DO NOT SCALE**

**IF IN DOUBT, ASK!**

REVISIONS

REV.	DESCRIPTION	DATE	DRAWN
1	FIRST ISSUE	10/10/2014	CC

NOTES:

1. THE SIZING AND DETAILED DESIGN OF THE LOAD-BEARING SUPPORTS MUST BE SIGNED OFF BY THE STRUCTURAL ENGINEER FOR THE PROJECT.
2. E-STACK UNIT SUPPLIED WITH 4 NO. MOUNTING BRACKETS. ROOF PROFILES ARE INDICATIVE.
3. SHAFT DIVIDER INSULATION NOT REQUIRED.
4. SHAFT DIVIDER MUST PRESERVE AIR-SEPARATION FROM ROOF TERMINAL TO E-STACK DAMPER.
5. BUILDERS TO CHECK STRUCTURAL OPENING SIZES AND REPORT TO BBL. IF NOT WITHIN TOLERANCES.
6. IF UNIT IS INSTALLED LESS THAN 2.7M ABOVE FINISHED FLOOR LEVEL, THEN FINGER GUARD GRILLES MUST BE SPECIFIED.
7. MUSHROOM ROOF TERMINAL UNITS MUST BE OFF-LOADED FROM DELIVERY WITH THE PROVIDED 'SOFT EYED 6M E.W.L. WEBBING SLINGS S.W.L. 1000KG'.

TOLERANCES EXCEPT WHERE OTHERWISE STATED

X	±	0.5MM
X.XX	±	0.05MM
ANGLES	±	0.5°

SURFACE TEXTURE TO BE 1.6 UMRA OR BETTER

DE-BURR ALL SHARP EDGES AND HOLES. ITEM MUST BE FREE FROM SCRATCHES, DENTS AND OTHER BLEMISHES.

DIMENSIONS IN MILLIMETRES



UNIT 3A, THE SHADE, SOHAM CB7 5HF  
T: 01223 450060 F: 01223 450061  
WWW.BREATHINGBUILDINGS.COM

TITLE:

S1200L INSTALLATION GA WITH MUSHROOM ROOF TERMINAL

DRAWING NO:

1341\_9003\_01

MATERIAL:

FINISH:

REV	DRAWN	DATE	CHK'D	DATE
1	CC	10/10/2014		

SCALE 1:25 A3 SHEET 1 OF 2

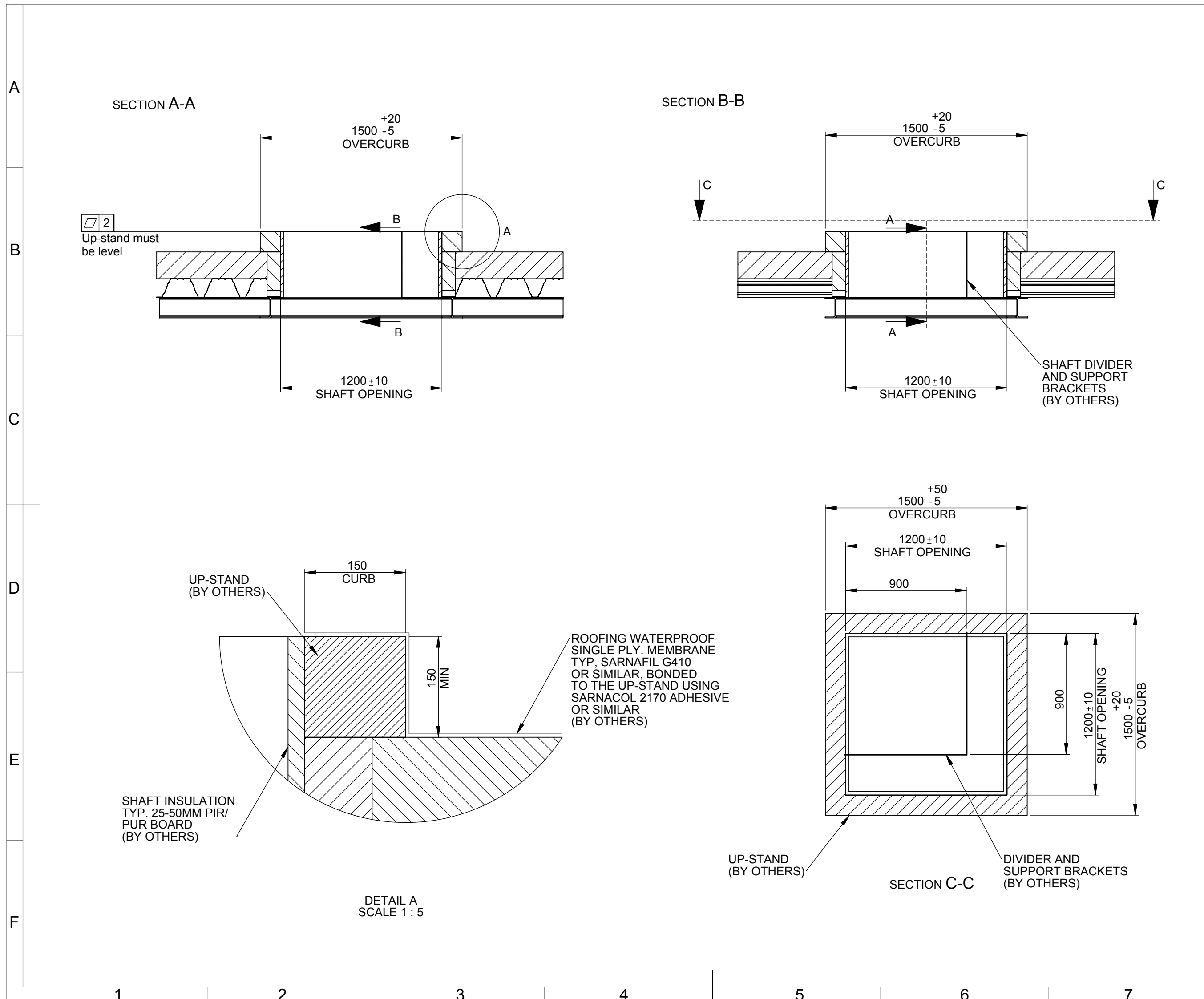

**DO NOT SCALE**

**IF IN DOUBT, ASK!**

REVISIONS

ZONE	REV.	DESCRIPTION	DATE	APPROVED
-	-	See Sheet1	-	-

NOTES:

1. THE SIZING AND DETAILED DESIGN OF THE LOAD-BEARING SUPPORTS MUST BE SIGNED OFF BY THE STRUCTURAL ENGINEER FOR THE PROJECT.
2. E-STACK UNIT SUPPLIED WITH 4 NO. MOUNTING BRACKETS.
3. ROOF PROFILES ARE INDICATIVE.
4. SHAFT DIVIDER INSULATION NOT REQUIRED.
5. SHAFT DIVIDER MUST PRESERVE AIR-SEPARATION FROM ROOF TERMINAL TO E-STACK DAMPER.
6. BUILDERS TO CHECK STRUCTURAL OPENING SIZES AND REPORT TO BBL. IF NOT WITHIN TOLERANCES.
7. IF UNIT IS INSTALLED LESS THAN 2.7M ABOVE FINISHED FLOOR LEVEL, THEN FINGER GUARD GRILLES MUST BE SPECIFIED.
8. MUSHROOM ROOF TERMINAL UNITS MUST BE OFF-LOADED FROM DELIVERY WITH THE PROVIDED 'SOFT EYED 6M E.W.L WEBBING SLINGS S.W.L 1000KG'.

TOLERANCES EXCEPT WHERE OTHERWISE STATED

X	±	0.5MM
X.XX	±	0.05MM
ANGLES	±	0.5°

SURFACE TEXTURE TO BE 1.6 UMRA OR BETTER

DE-BURR ALL SHARP EDGES AND HOLES ITEM MUST BE FREE FROM SCRATCHES, DENTS AND OTHER BLEMISHES.

DIMENSIONS IN MILLIMETRES



1 UNIT 3A, THE SHADE, SOHAM CB7 5HF  
T: 01223 450060 F: 01223 450061  
WWW.BREATHINGBUILDINGS.COM

TITLE:

S1200L INSTALLATION GA WITH MUSHROOM ROOF TERMINAL

DRAWING NO:

1341\_9003\_01

MATERIAL:

FINISH:

REV	DRAWN	DATE	CHK'D	DATE
1	CC	10/10/2014		

SCALE 1:25 A3 SHEET 2 OF 2

SECTION D-D

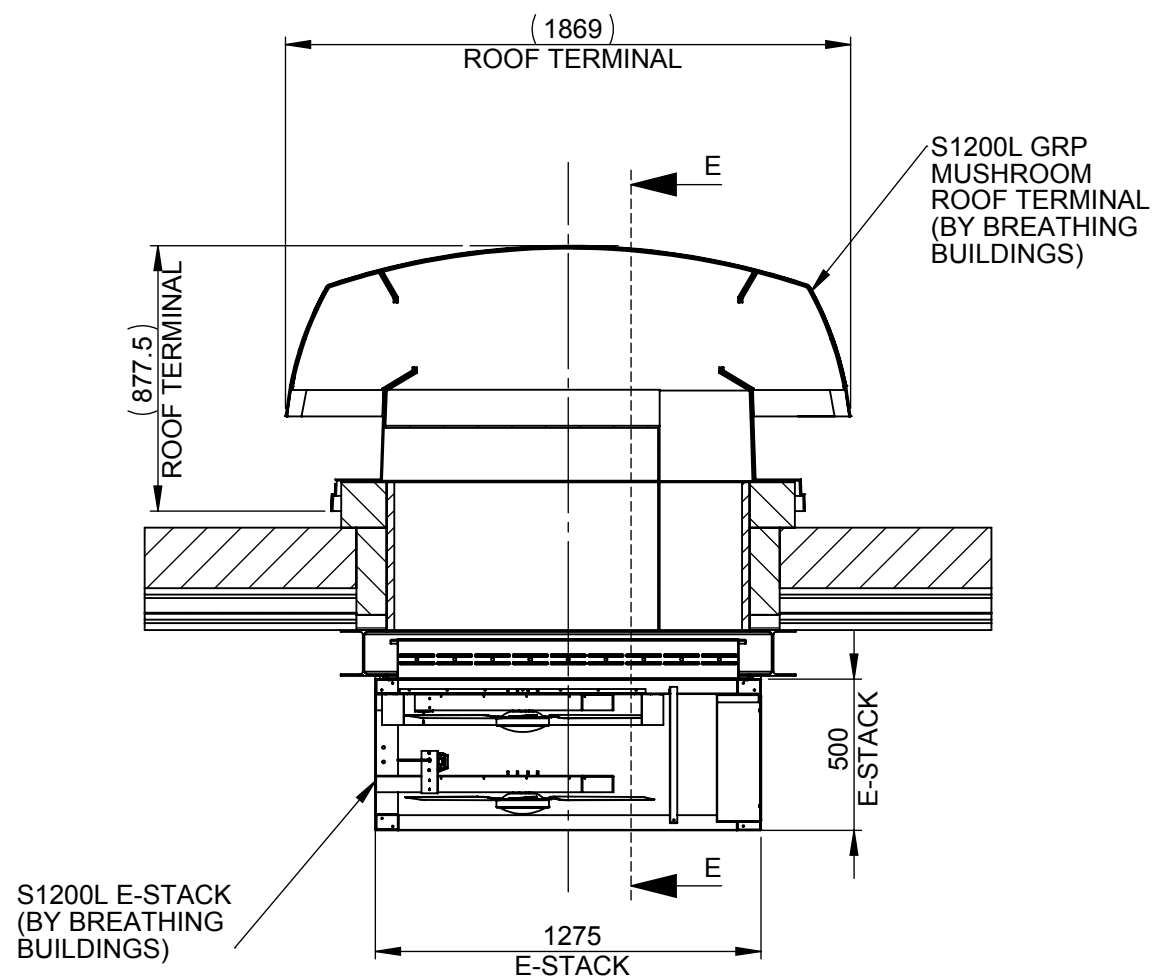

SECTION E-E

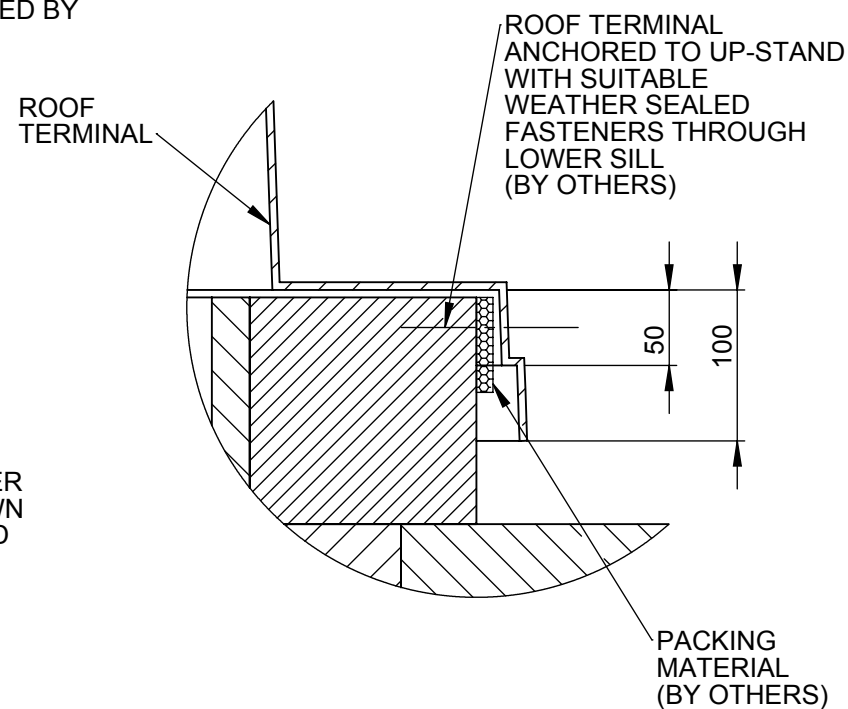
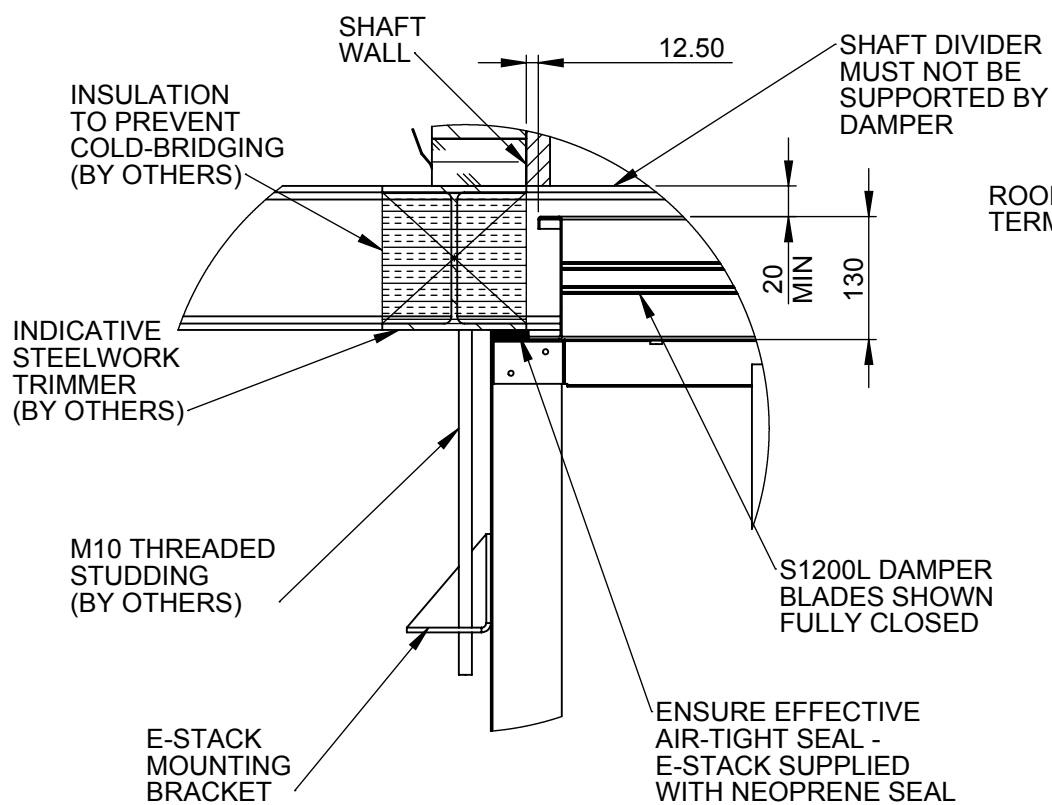
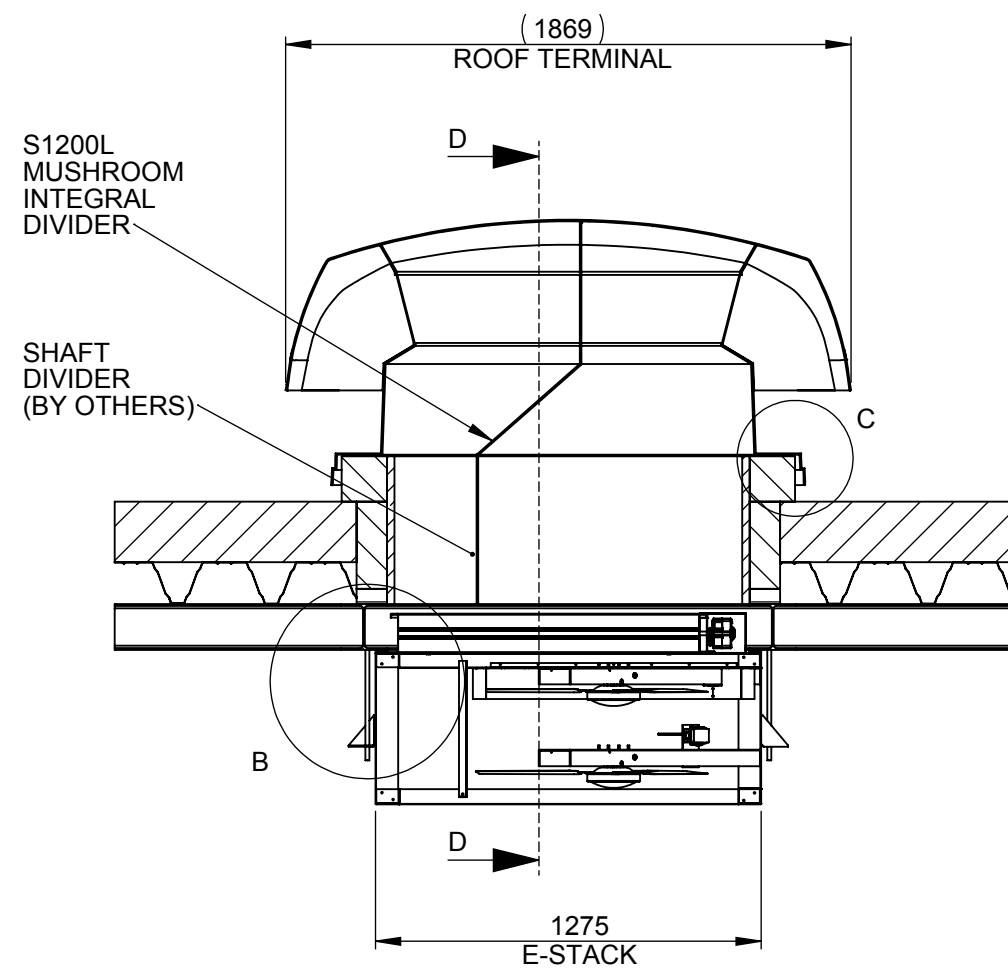

UP-STAND MATERIAL	FASTENERS
CONCRETE	STAINLESS STEEL M6 RESIN ANCHOR
TIMBER	STAINLESS STEEL M6 BOLT OR 5MM DIA SCREW
STEEL	STAINLESS STEEL 5MM DIA SELF-DRILLING SCREW
MASONRY	NOT RECOMMENDED