

DO NOT SCALE

IF IN DOUBT, ASK!

REVISIONS			
REV.	DESCRIPTION	DATE	DRAWN
1	FIRST ISSUE	05/03/2015	CC
2	NOTES	04/04/2015	DP
3	NOTES	25/06/2015	CC
4	UPDATED WEIGHT	12/08/2016	CC

NOTES:

- R-SERIES UNIT FINISHED IN GALV. AS STANDARD. RAL COLOURS AVAILABLE ON REQUEST AT ADDITIONAL COST.
- MIXED AIR DELIVERY OUTLET THROUGH "B" SIDE AS STANDARD. UNIT SUPPLIED WITH 4 NO. MOUNTING BRACKETS AS SHOWN AS STANDARD.
- UNIT CAN BE HUNG FROM M10 STUDDING THROUGH FIXING BRACKETS. UNIT SHOWN WITHOUT GRILLES. GRILLES AVAILABLE ON REQUEST AT ADDITIONAL COST.
- IF UNIT IS POSITIONED LESS THAN 2.7m ABOVE GROUND, FINGER GUARD GRILLES MUST BE USED.
- DIVIDER TO BE ALIGNED WITH SIMILAR DIVIDER IN SHAFT AND ROOF TERMINAL DURING INSTALLATION TO CREATE TWO AIR PATHWAYS.
- DAMPER PHYSICAL FREE AREA 0.82M². DAMPER FINISH RAL 9005 GLOSS 70.

4X ANGLE BRACKETS REFER TO DRAWING 1505-9000

PLAN VIEW

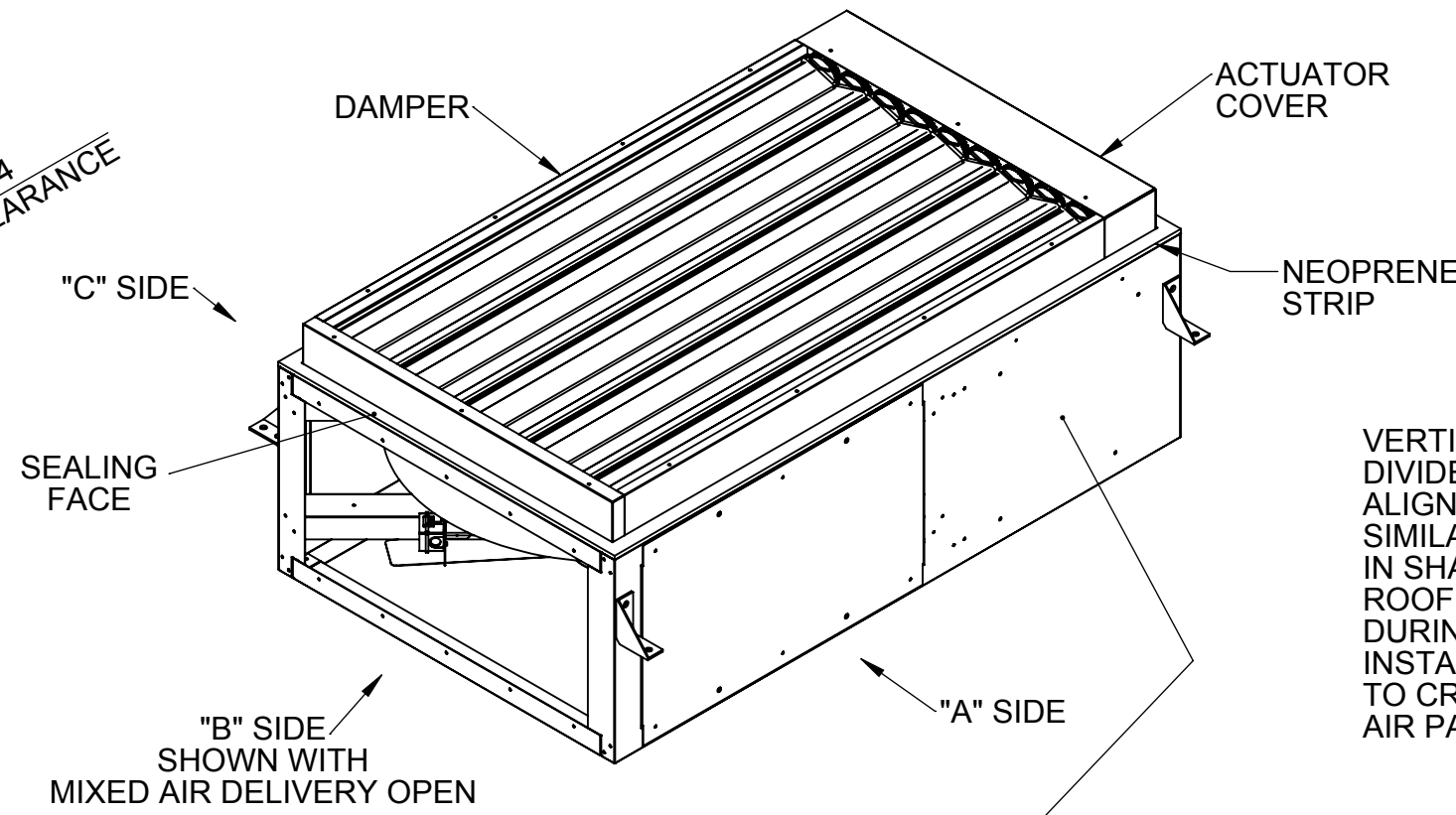
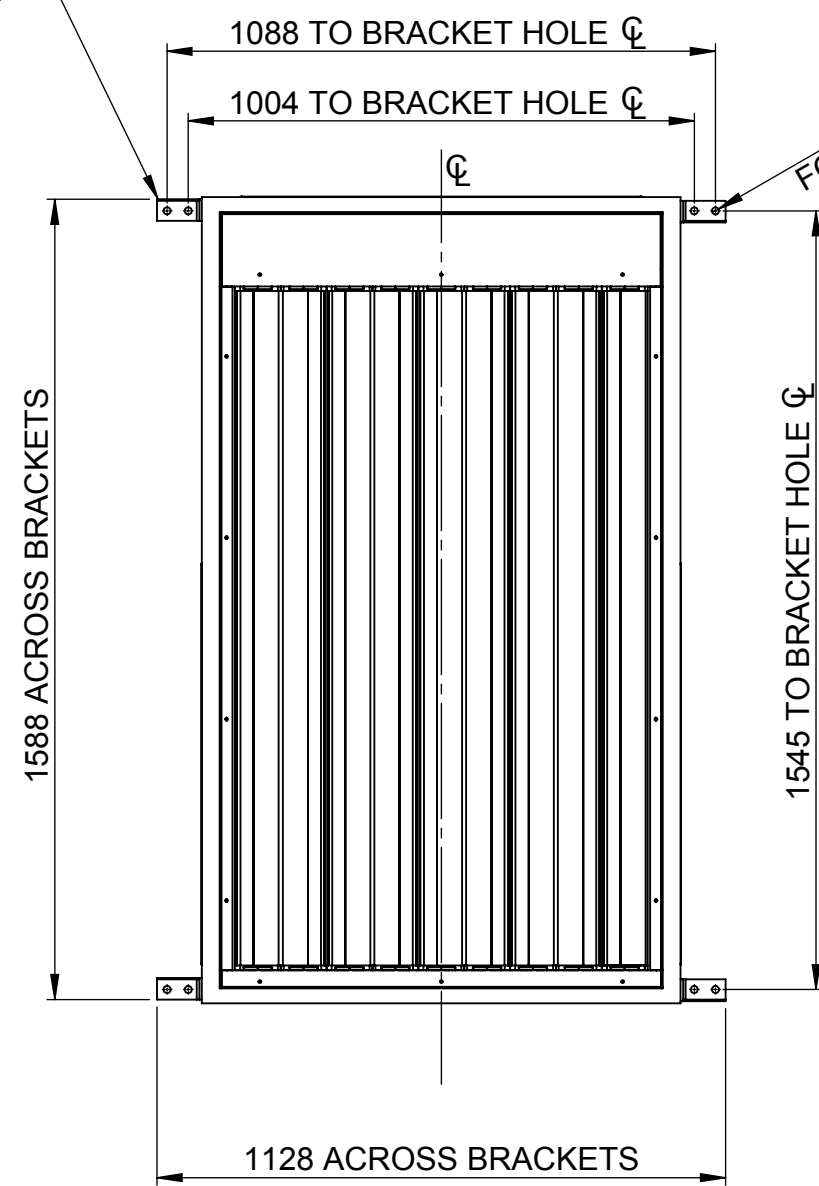

VERTICAL DIVIDER TO BE ALIGNED WITH SIMILAR DIVIDER IN SHAFT AND ROOF TERMINAL DURING INSTALLATION TO CREATE TWO AIR PATHWAYS

R-SERIES SHOWN IN-CONTEXT OF INSTALLATION WITH GRP MUSHROOM ROOF TERMINATION TO SHOW VERTICAL DIVIDER.

REFER TO INSTALLATION DRAWINGS FOR DIMENSIONS AND INSTALL DETAIL.

Up-stand must be level

ENSURE GOOD SEALING FACE

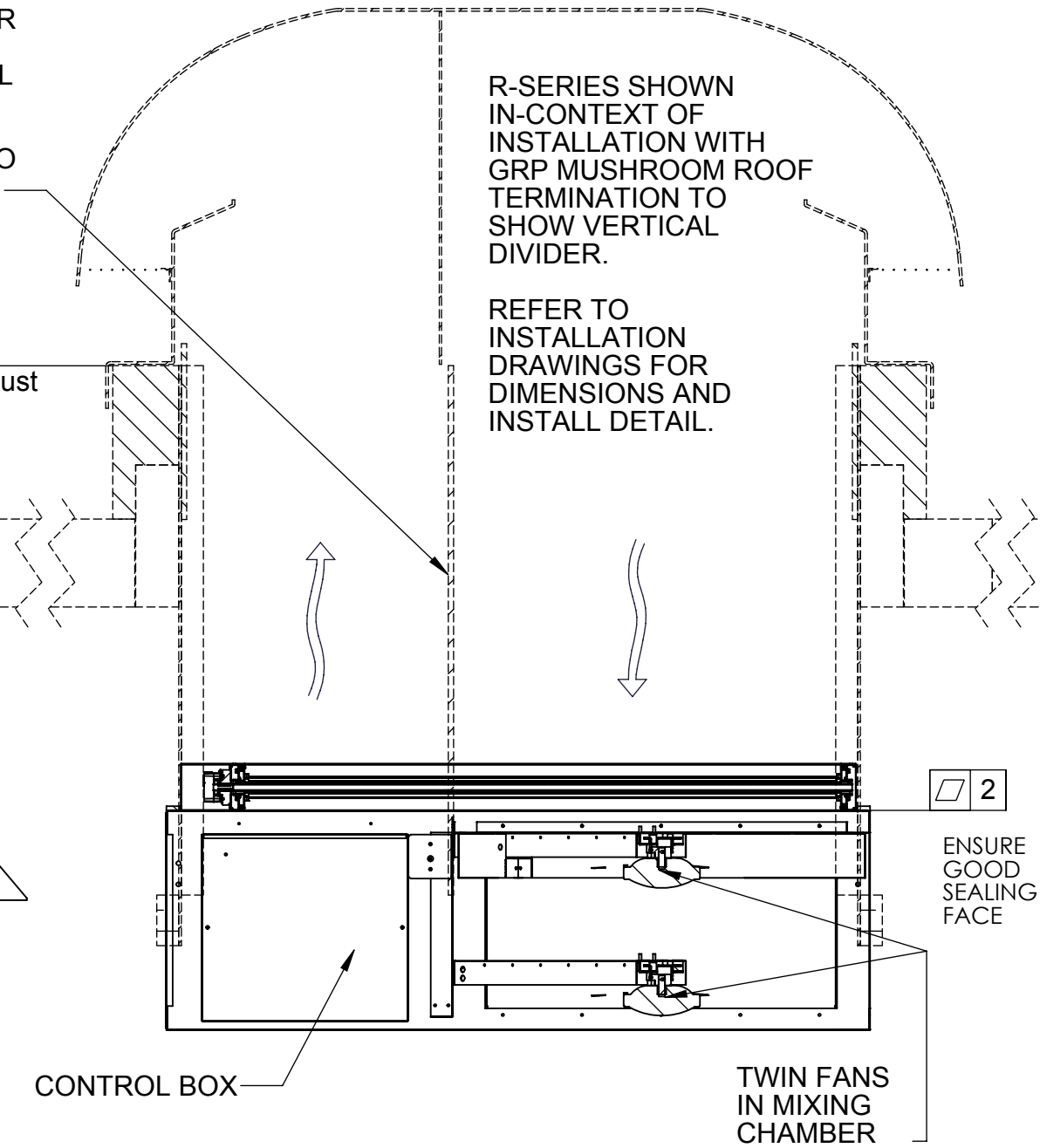
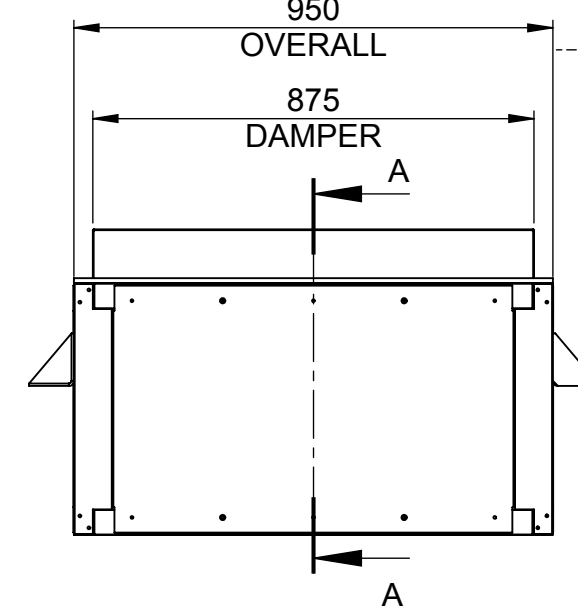
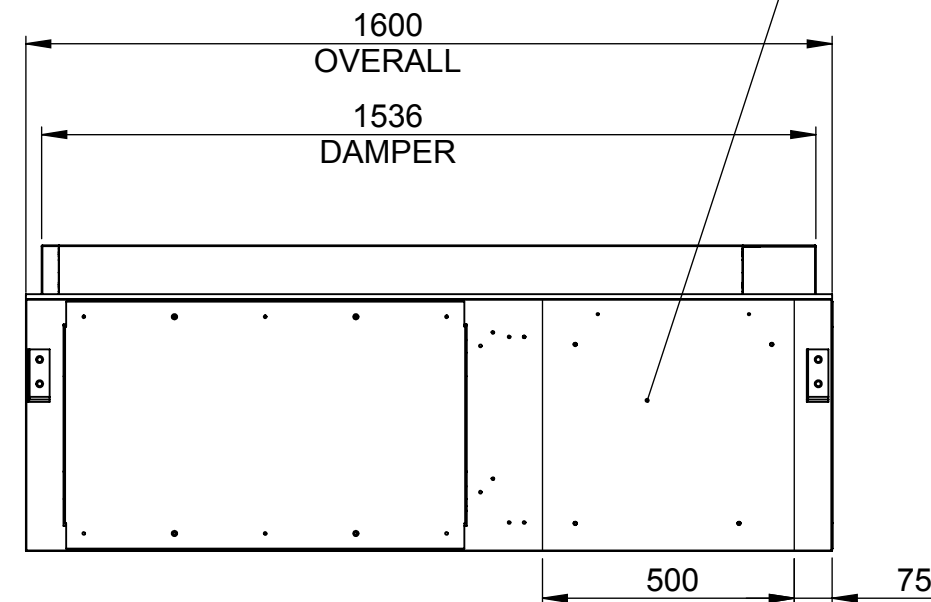
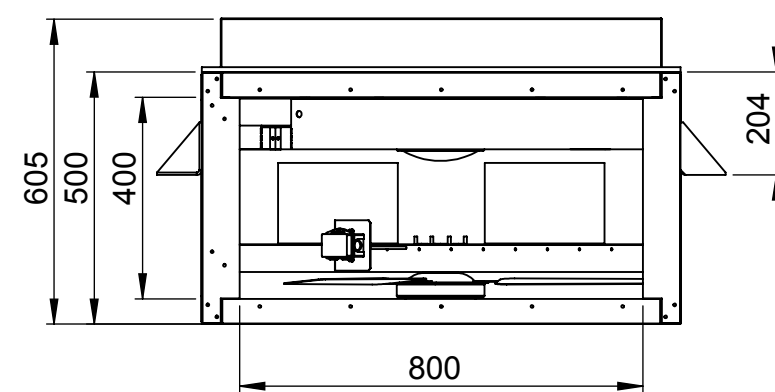

"B" SIDE (SHOWN WITH MIXED AIR DELIVERY OPEN)

"A" SIDE (SHOWN WITH MIXED AIR DELIVERY CLOSED)

SECTION A-A

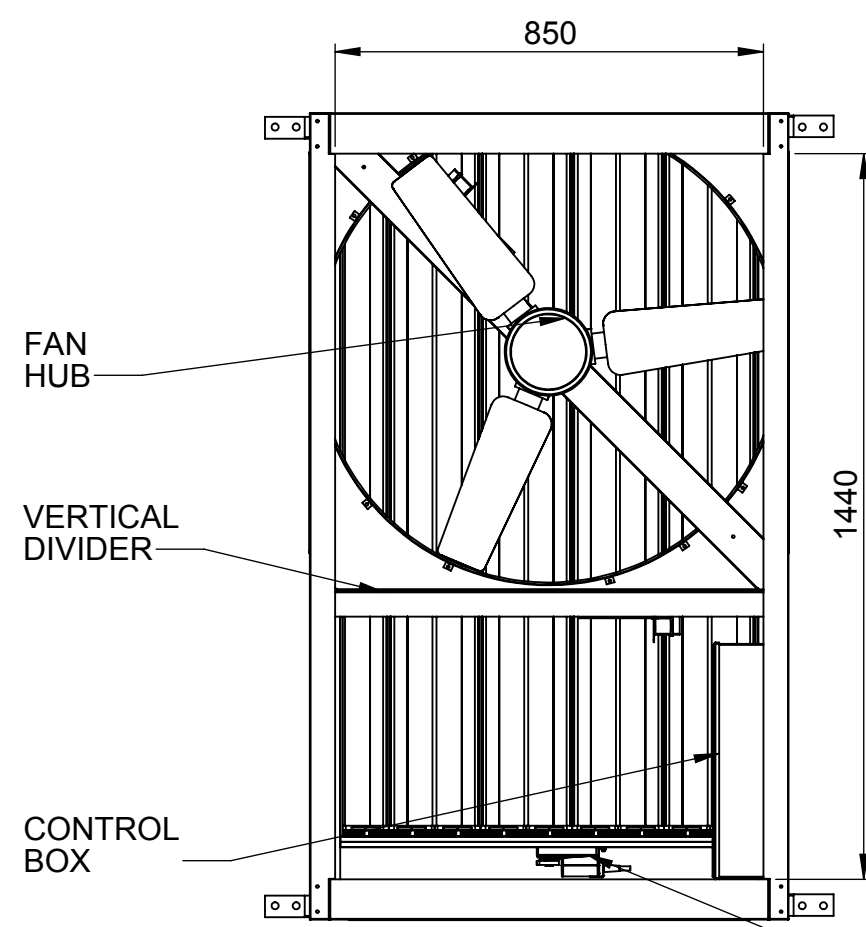

UNDERSIDE VIEW

ACTUATOR MAINTENANCE FROM UNDERSIDE OF E-STACK

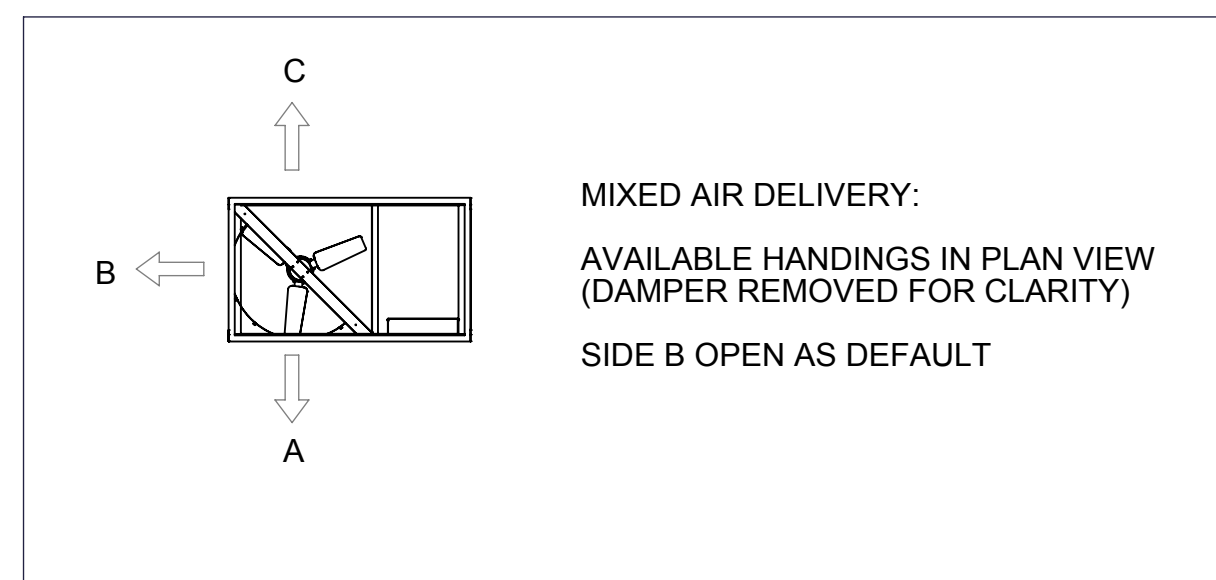

MIXED AIR DELIVERY: AVAILABLE HANDINGS IN PLAN VIEW (DAMPER REMOVED FOR CLARITY) SIDE B OPEN AS DEFAULT



MATERIAL: MILD STEEL

FINISH GALV. OR POWDER COAT ZINTEC

MASS WITHOUT PACKAGING 106KG

TOLERANCES EXCEPT WHERE OTHERWISE STATED

X : 0.5MM, X.XX : 0.05MM, ANGLES : 0.5°

SURFACE TEXTURE TO BE 1.6 UMRA OR BETTER

DE-BURR ALL SHARP EDGES AND HOLES. ITEM MUST BE FREE FROM SCRATCHES, DENTS AND OTHER BLEMISHES.

DIMENSIONS IN MILLIMETRES



UNIT 3A, THE SHADE, SOHAM, CB7 5HF T: 01223 450060 F: 01223 450061 www.breathingbuildings.com/products

TITLE: E-STACK: R-SERIES VERSION 6

DRAWING NO:

1332_9201

REV	DRAWN	DATE	CHKD	DATE
4	CC	12/08/2016		

SCALE 1:15 A2 SHEET 1 OF 2

DO NOT SCALE

IF IN DOUBT, ASK!

REVISIONS

REV.	DESCRIPTION	DATE	APPROVED
-	See Sheet1	-	-

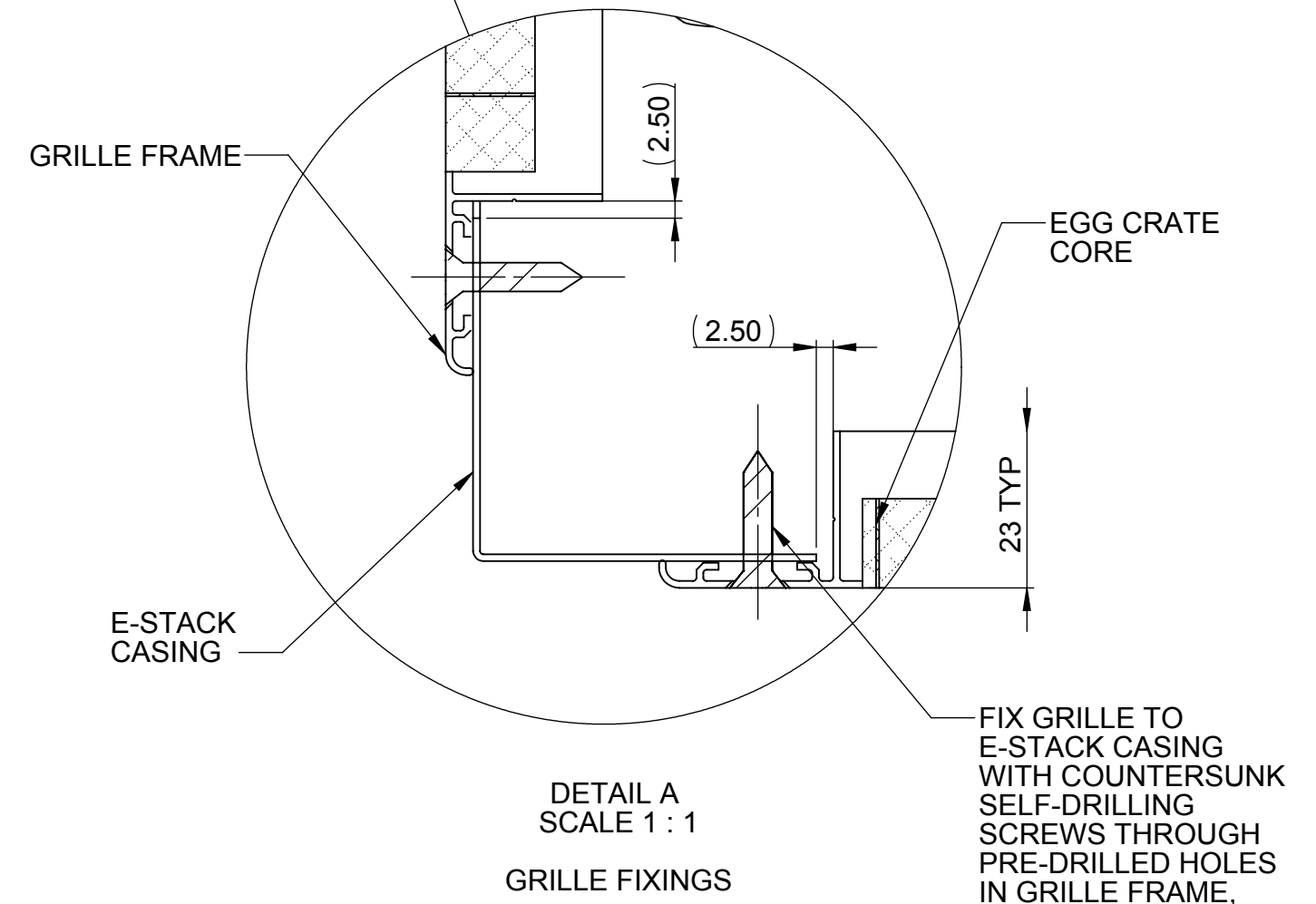
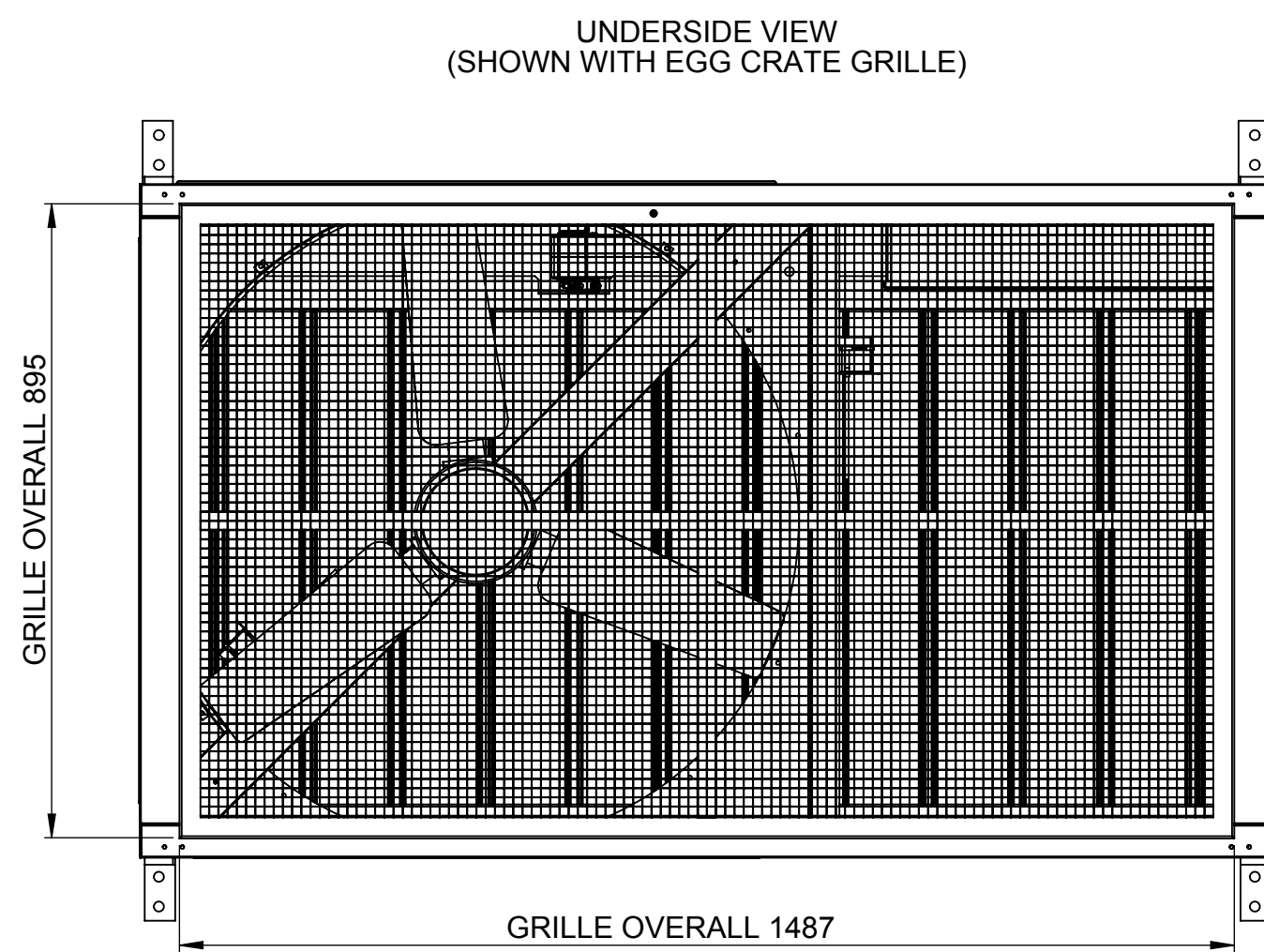
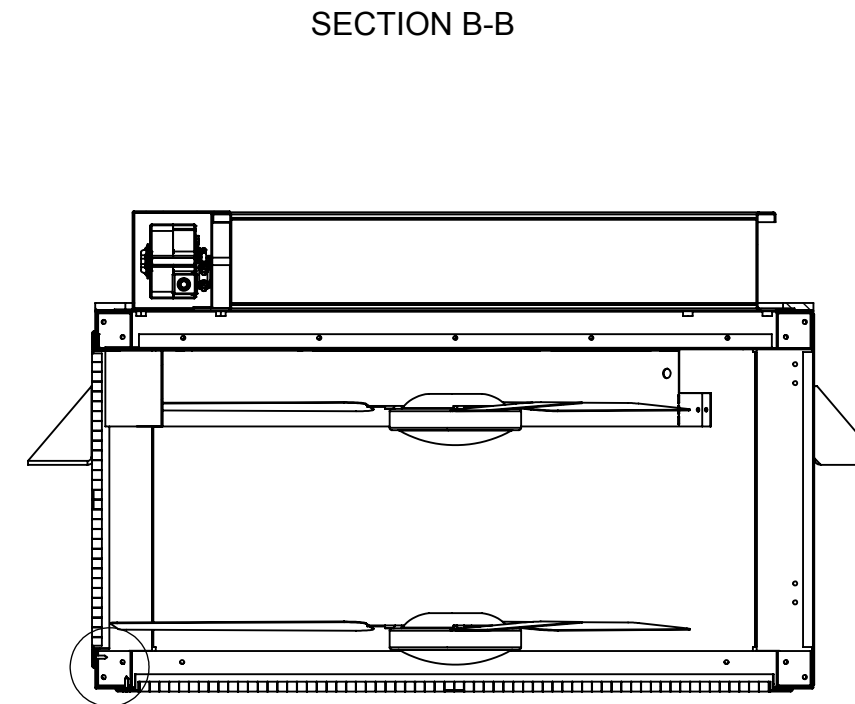
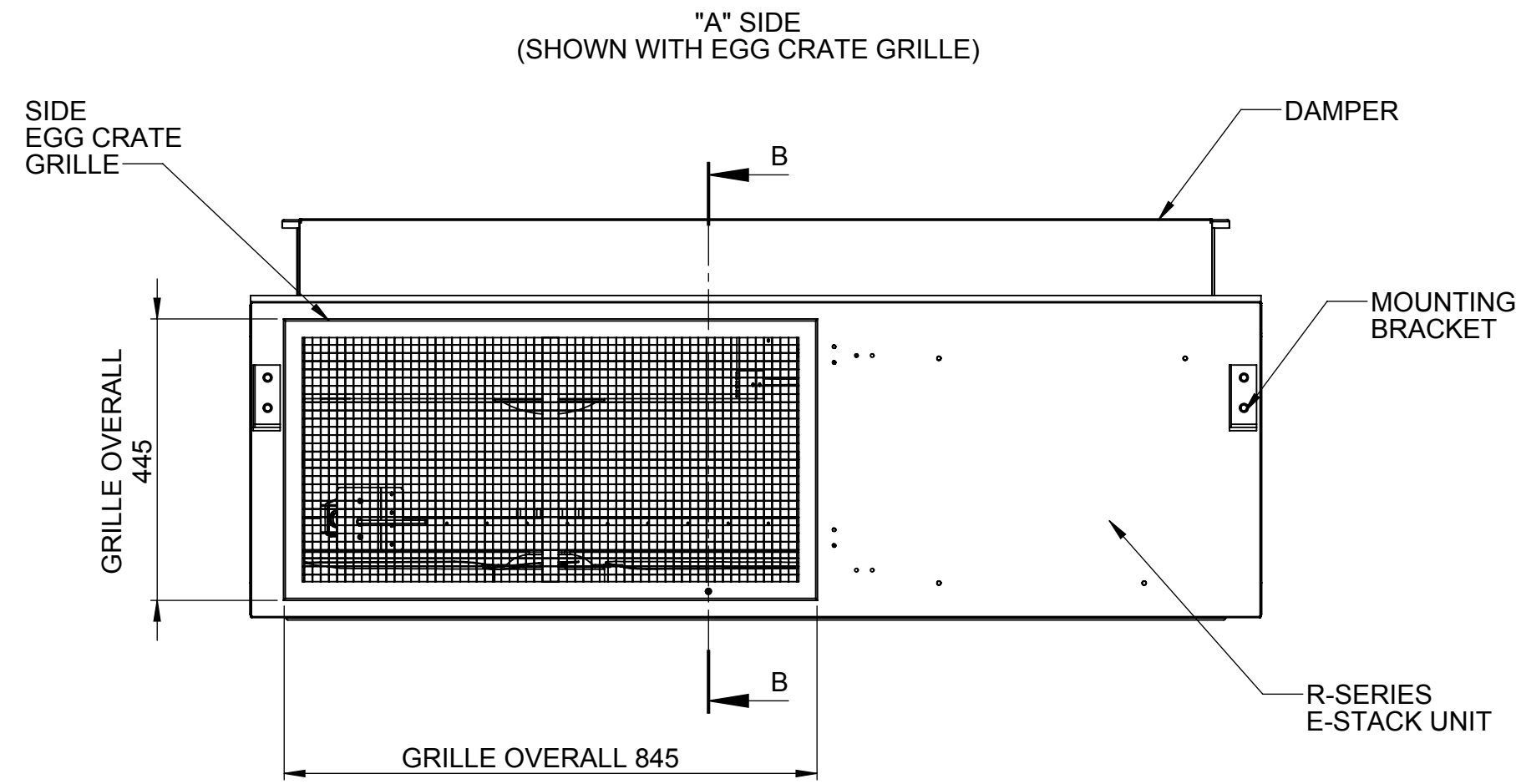

MATERIAL:
MILD STEEL

FINISH
GALV. OR POWDER COAT ZINTEC

MASS WITHOUT PACKAGING
106KG

TOLERANCES EXCEPT WHERE OTHERWISE STATED

X	:	0.5MM
X.XX	:	0.05MM
ANGLES	:	0.5°

SURFACE TEXTURE TO BE 1.6 UMRA OR BETTER

DE-BURR ALL SHARP EDGES AND HOLES. ITEM MUST BE FREE FROM SCRATCHES, DENTS AND OTHER BLEMISHES.

DIMENSIONS IN MILLIMETRES

GRILLE OPENING	
POSITION	APERTURE DIMENSION
SIDE	800X400
UNDERSIDE	1442X850

HEIGHT FROM FINISHED FLOOR LEVEL TO UNDERSIDE OF E-STACK	TYPE	OPEN AREA
>2.7M	EGG CRATE	12MM
<2.7M	FINGER GUARD	<8MM



UNIT 3A, THE SHADE, SOHAM, CB7 5HF T:
01223 450060 F: 01223 450061
www.breathingbuildings.com/products

TITLE:

DRAWING NO:
1332_9201

REV	DRAWN	DATE	CHKD	DATE
4	CC	12/08/2016		

SCALE 1:10 A2 SHEET 2 OF 2