

Breathing Buildings NVHR 900+

The incorporation of a heater into the NVHR system allows room pre-heating, and enhanced control over the temperature of air being delivered to the space during occupancy. The combined LTHW heating and ventilation unit means the two services are integrated and optimised for the most efficient use of heating and electrical energy.

The low energy heating and mixing ventilation system makes the most of free internal heat gains to temper incoming fresh air in winter, while also providing:

- Frost protection
- Pre-occupancy space heating
- Enhanced control over delivered air temperature
- Quick-response heating compared to other heating methods
- Avoidance of over-supplying heat to the space
- Negates requirement for other sources of heating in the room
- Integral controller and Temp/CO2 sensors
- Set-points adjustable via BMS
- Automatic operation with user override
- Winter mixing
- Summer boost
- Automatic summer night cooling

The system typically works as a single unit in small offices, multiple units in large offices and a standard pair of units in typical school classrooms.

Morning pre-heat

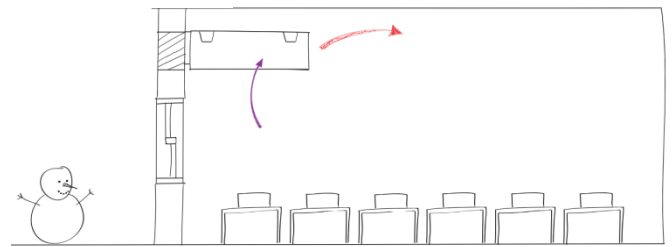

Occupied day heating

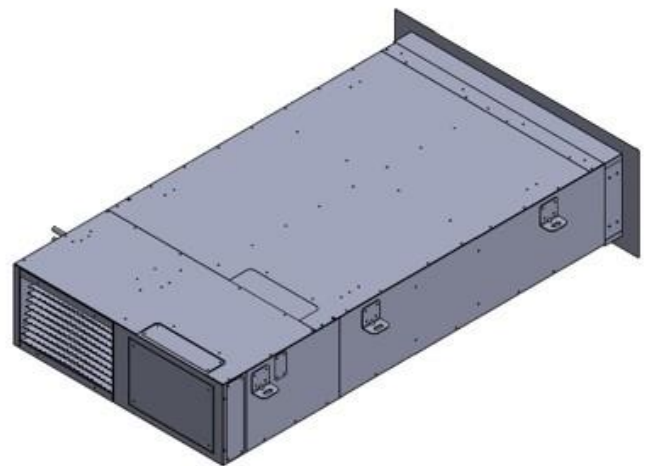
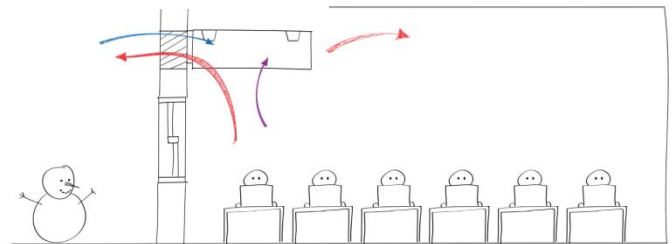

Heating duty	Normal Daytime Mode: 3.14 kW per NVHR+ unit (6.28 kW per pair) Morning Pre-heat Mode: 3.16 kW per NVHR+ unit (6.32 kW per pair) Science Lab Practical Mode: 4.24 kW per NVHR+ unit (8.48 kW per pair)
Heating medium	Water entering 80 °C leaving 60 °C @ 0.03 – 0.05 l/s
LTHW connections	15 mm copper tubing.
Heating valve	Two-port pressure independent control valve (by others), controlled by a modulating 0-10V actuator, 24Vdc.
Specific Fan Power	0.16 – 0.29 W/l/s (depends on mode of operation)

IF IN DOUBT ASK!

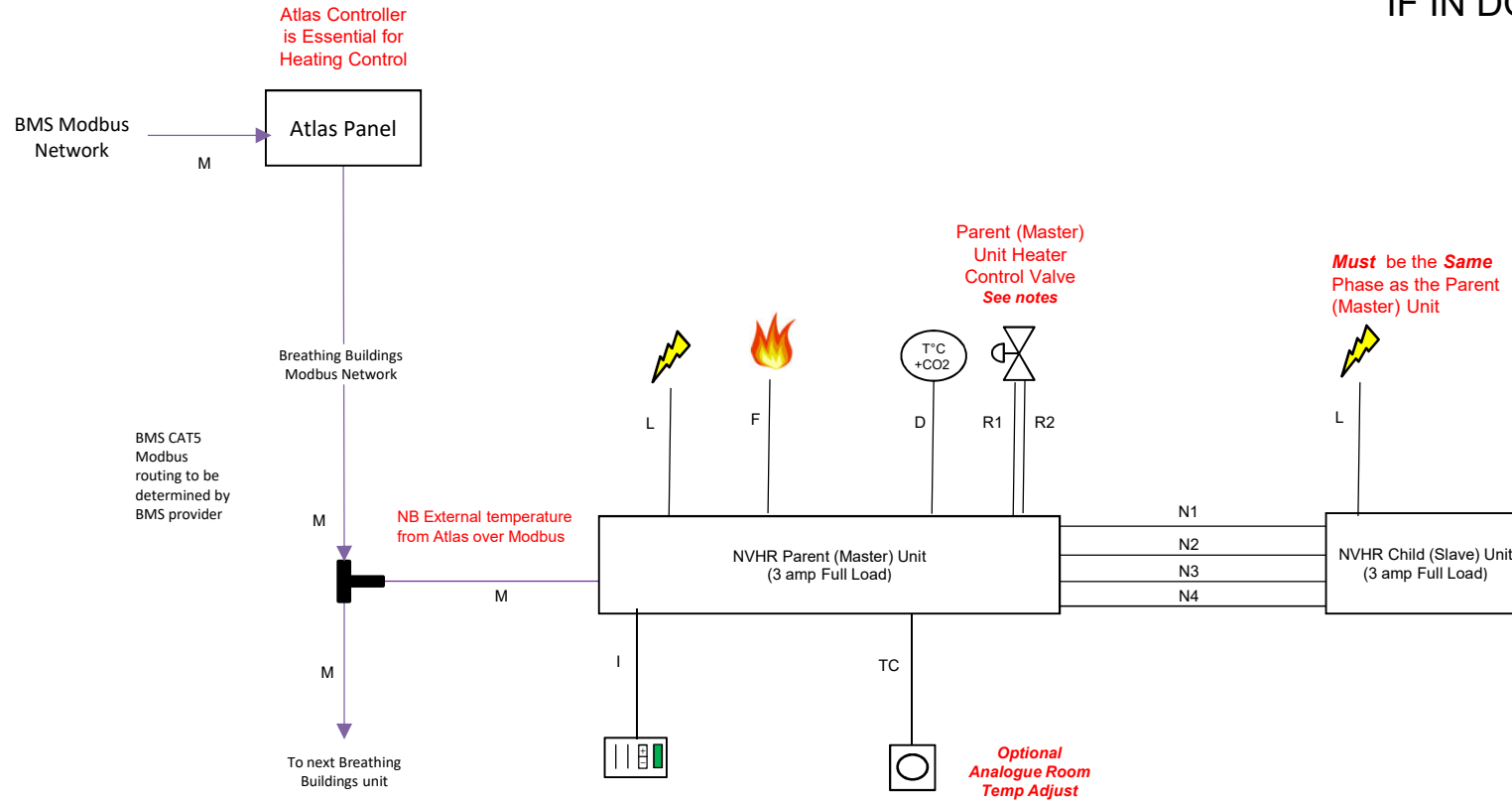

Ident	Device	Cable Description	Power Rating
D	Internal Temperature/ CO ₂ Sensor	4 core shielded (24vdc, 0v, 10vdc signal 1, 10vdc signal 2, shield)	3W at 24V DC
F	Fire Healthy Signal	FP200 (24vdc switch supply, Fire Signal, Earth)	Nom
I	User Interface – Type 1 For Type 2 see Notes	4 core (24V, 0V, 24vdc switch position Auto, 24vdc switch position Test) AND 4 core (24vdc switch position max Vent, 24vdc switch position Disable, 24vdc signal Window Indicator, 0v)	3W at 24V DC
L	Single phase mains power	3 core (230vac, N, PE).	230Vac @ 3A (FLC)
M	Modbus	Cat 5 with RJ45 straight through	N/A
N1	NVHR Child (Slave) Damper	3 core (24vdc, 0v, 24vdc signal 1)	3W at 24V DC
N2	NVHR Child (Slave) Fans	4 core (10vdc signal 1, 0v signal 1, 10vdc signal 2, 0v signal 2)	3W at 24V DC
N3	NVHR Child (Slave) Fans Feedback	4 core shielded (Feedback signal 1 & 0v, Feedback signal 2 & 0v, shield)	3W at 24V DC
N4	NVHR Child (Slave) Duct Sensor	4 core shielded (10vdc signal, 0v, 24vdc, spare, shield)	3W at 24V DC
R1	Two Port Radiator Valve Power	Valve Actuator Dependant (TBC)	TBC
R2	Two Port Radiator Valve Signal	3 core (10vdc signal, 0vdc, Earth)	3W at 24V DC
TC	Room Temp Adjustment Control	3 core (10vdc signal, 24vdc, 0vdc)	3W at 24V DC

Notes:

- Grilles to be removed by others / not fitted before Final Inspection
- Modbus is only required when communication is required between the Breathing Buildings unit and a main control panel or a BMS. See Breathing Buildings Modbus Networks notes below.
- Mains Distribution panels should use an appropriate **MCB** and **not** an **RCBO** as the Breathing Buildings units are fitted with mains filters, and when multiple are deployed the total residual current may cause an RCBO to trip and remove power.
- Cable recommended stranded 0.75mm² core min.
- Cable size and voltage drop to be calculated by others
- Cable not marked "shielded" can be site PVC mains rated LSF Cable
- Mains Fused Isolator External to E-Stack and approx. 2mt above room floor
- Fire Healthy signal supply shut off NB Damper will remain in position at time of power removal.
- Two Port Modulated Motorised Valve to be confirmed.
- N1 and N2 may be combined into a single cable.
- N3 and N4 must be screened in order to maintain signal integrity.
- Cables and terminations to be fully identified and numbered

TITLE
Wiring Diagram for NVHR with Heater Pod - Pair
PROJECT
SAMPLE
DRAWING NO.
0000-141110-01