

DO NOT SCALE

IF IN DOUBT, ASK!

REVISIONS			
REV.	DESCRIPTION	DATE	DRAWN
1	FIRST ISSUE	05/03/2015	CC
2	Minor annotation updates	04/04/2015	DP
3	MINOR UPDATE	25/06/2015	CC

Notes:

- R-Series unit finished in galv. as standard. RAL colours available on request at additional cost.
- Mixed air delivery outlet through "B" side as standard.
- Unit supplied with 4 no. mounting brackets as shown as standard. Unit can be hung from M10 studding through fixing brackets.
- Unit shown without grilles. Grilles available on request at additional cost. If unit is positioned less than 2.7m above ground, finger guard grilles must be used.
- Divider to be aligned with similar divider in shaft and roof terminal during installation to create two air pathways.
- Damper physical free area 0.82m<sup>2</sup>. Damper finish RAL 9005 gloss 70.

4X ANGLE BRACKETS REFER TO DRAWING 1505-9000

PLAN VIEW

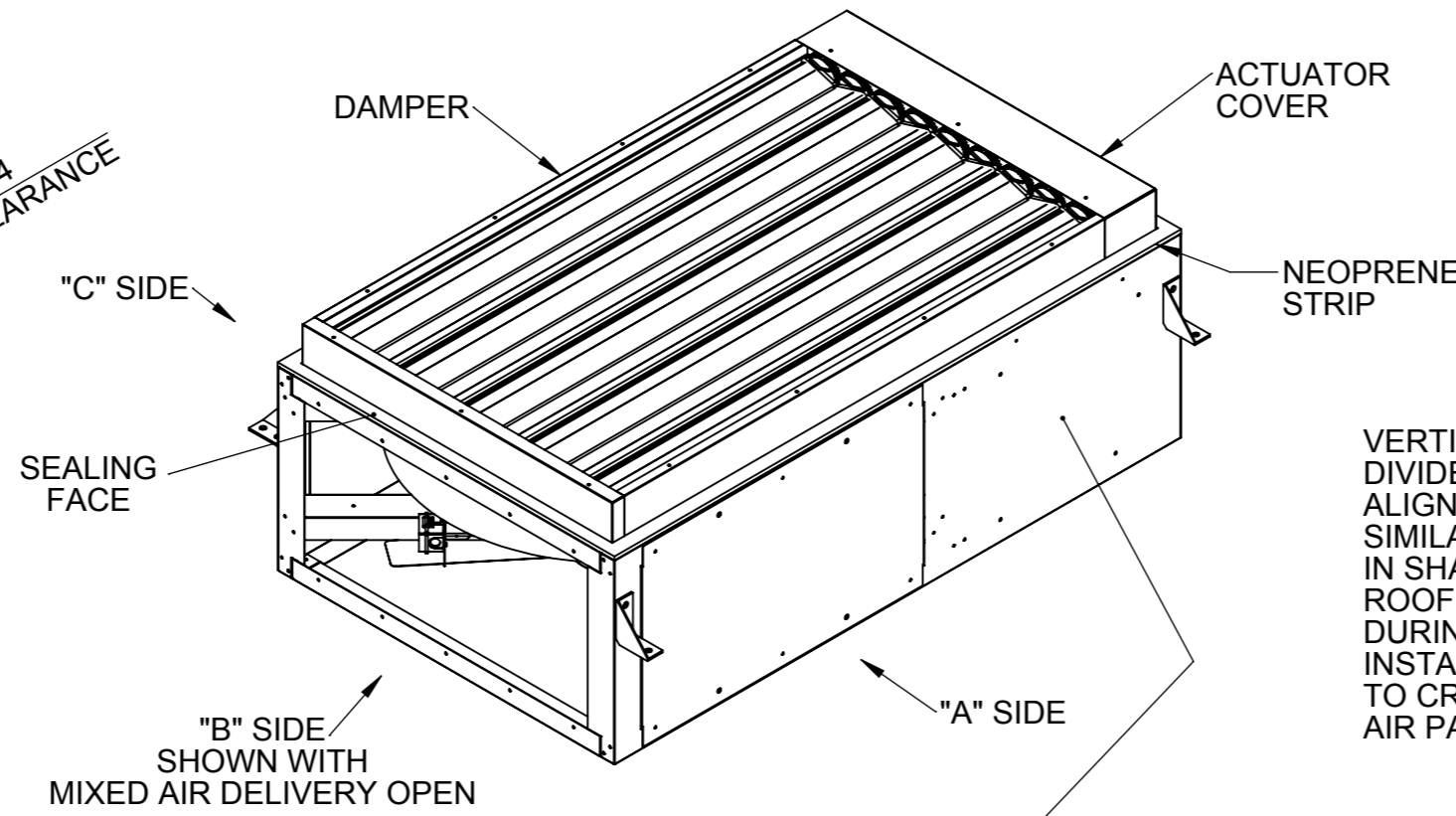
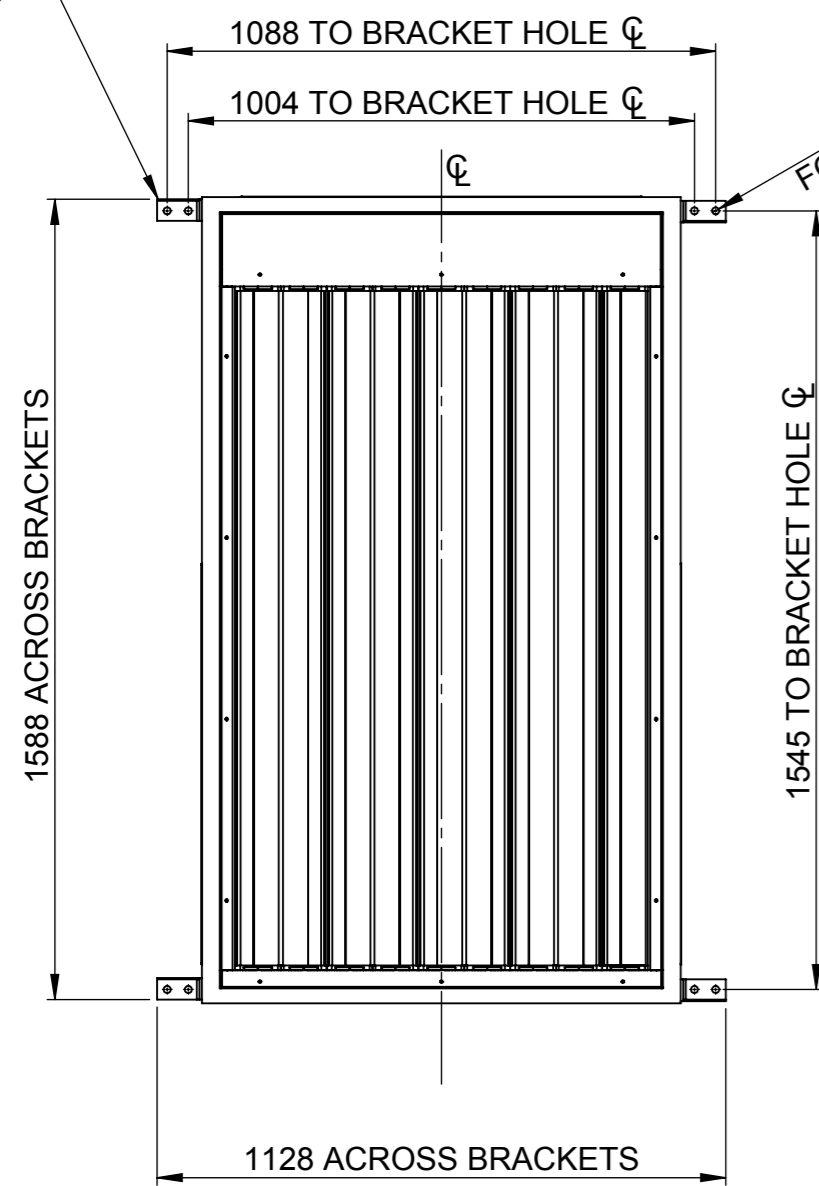

VERTICAL DIVIDER TO BE ALIGNED WITH SIMILAR DIVIDER IN SHAFT AND ROOF TERMINAL DURING INSTALLATION TO CREATE TWO AIR PATHWAYS

CONTROL BOX LOCATION DO NOT DRILL THROUGH THIS AREA - ACCESS FOR CABLES TO LEFT SIDE OF SPACE ENVELOPE (500X500)

Up-stand must be level

R-SERIES SHOWN IN-CONTEXT OF INSTALLATION WITH GRP MUSHROOM ROOF TERMINATION TO SHOW VERTICAL DIVIDER.

REFER TO INSTALLATION DRAWINGS FOR DIMENSIONS AND INSTALL DETAIL.

ENSURE GOOD SEALING FACE

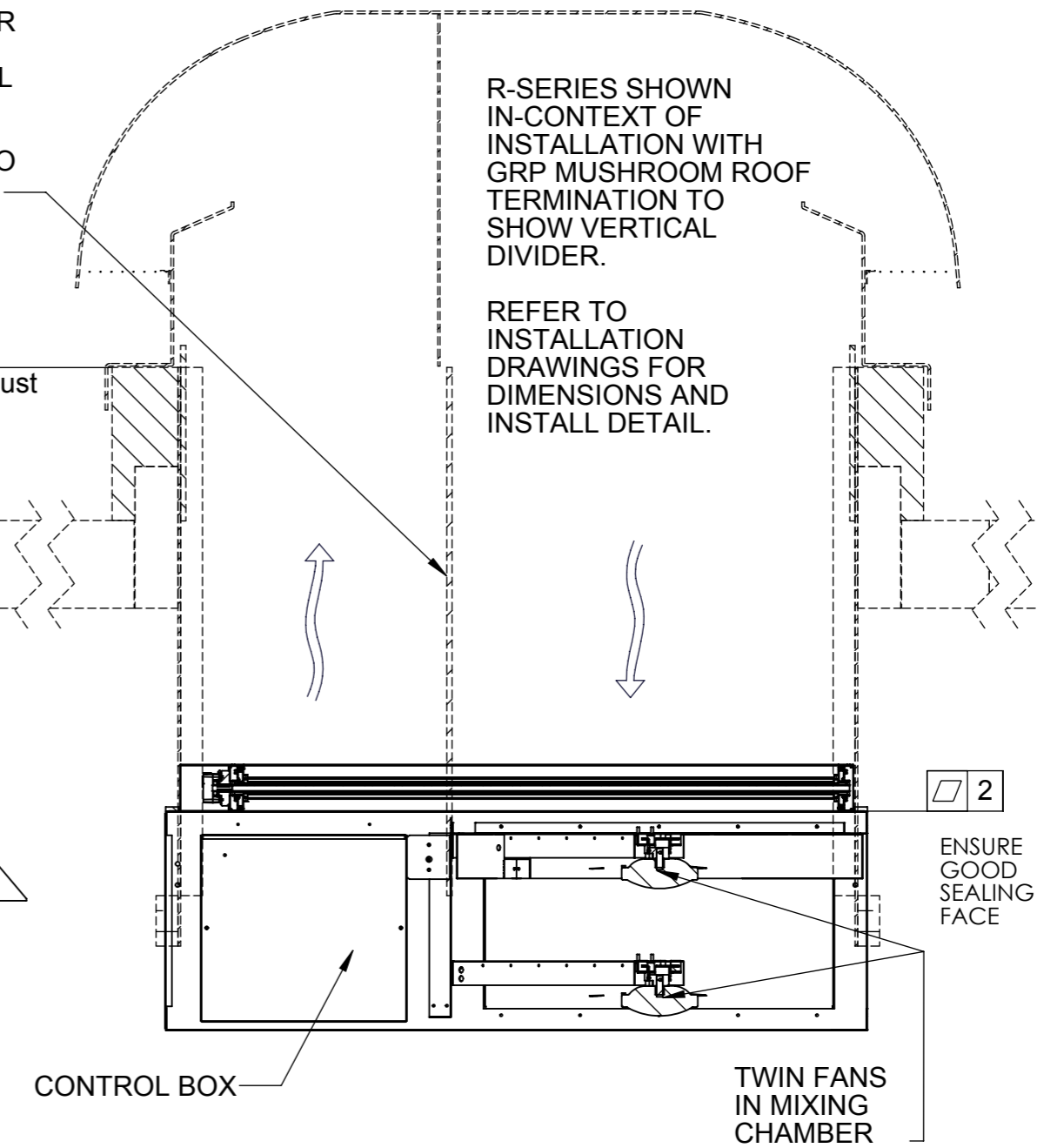
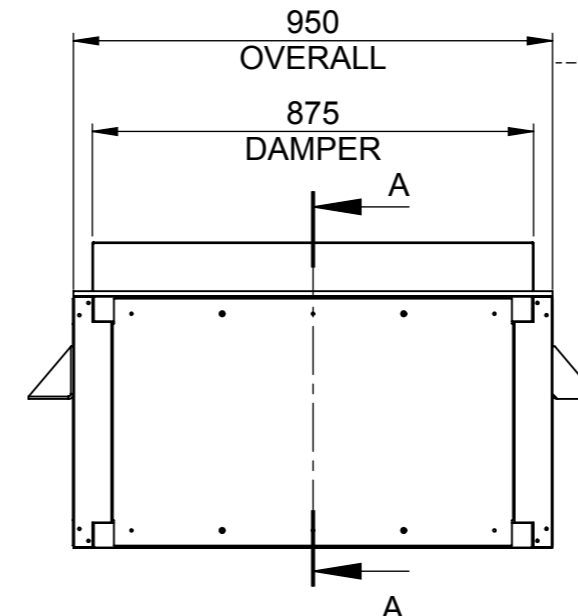
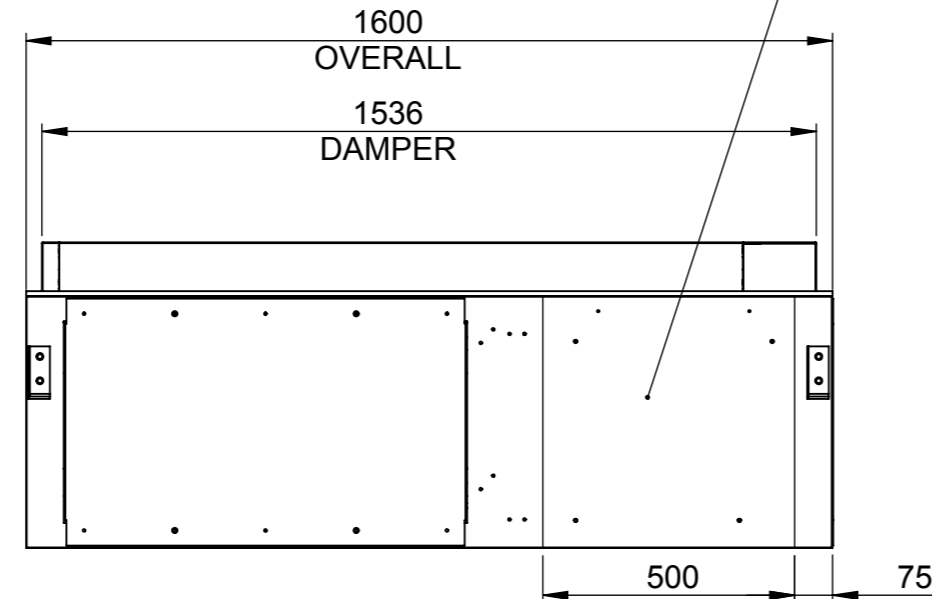
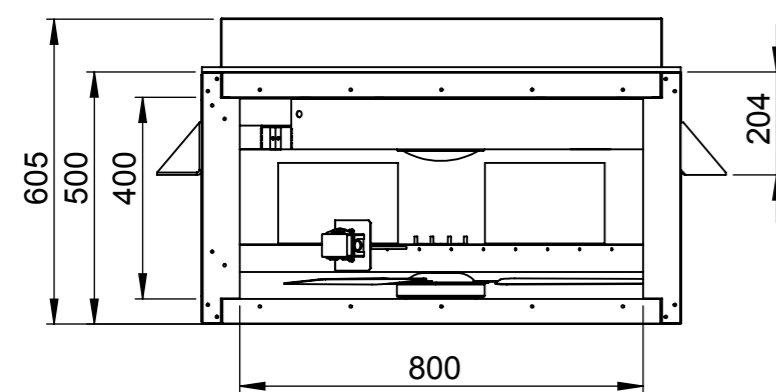

"B" SIDE (SHOWN WITH MIXED AIR DELIVERY OPEN)

"A" SIDE (SHOWN WITH MIXED AIR DELIVERY CLOSED)

SECTION A-A

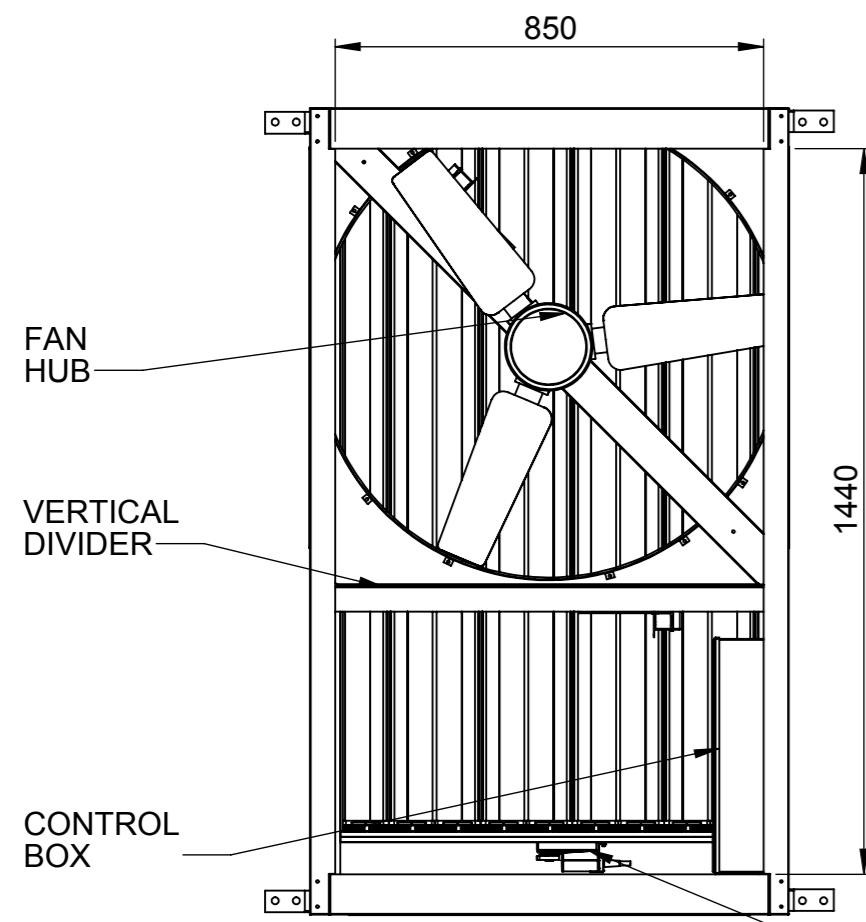

UNDERSIDE VIEW

ACTUATOR MAINTENANCE FROM UNDERSIDE OF E-STACK

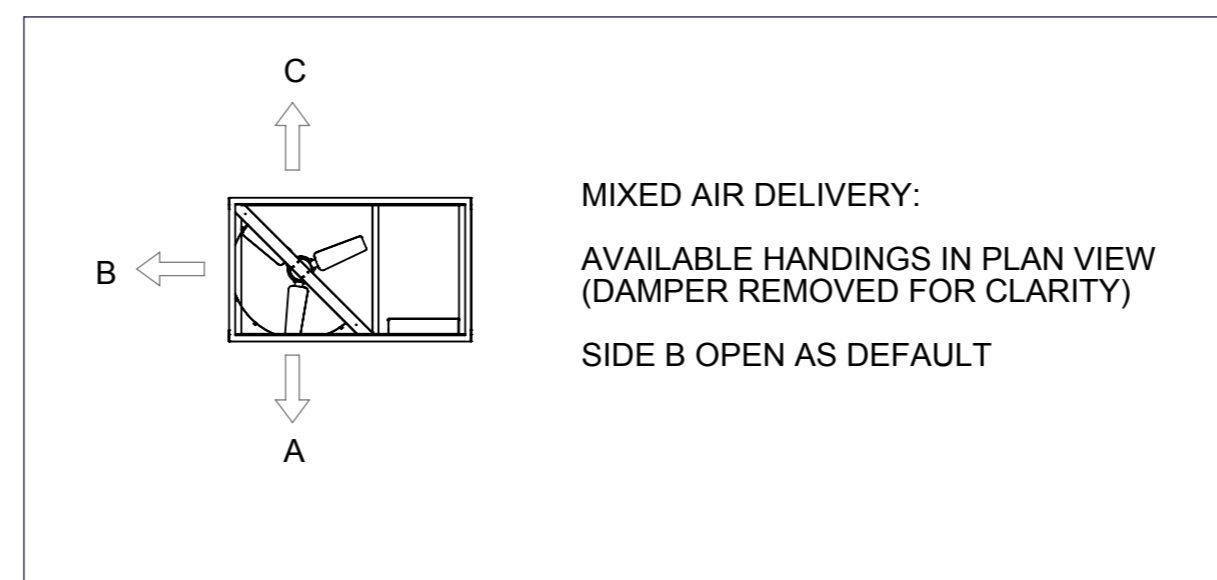

MATERIAL: MILD STEEL

FINISH GALV. OR POWDER COAT ZINTEC

MASS WITHOUT PACKAGING <86KG

TOLERANCES EXCEPT WHERE OTHERWISE STATED

X : 0.5MM  
X.XX : 0.05MM  
ANGLES : 0.5°

SURFACE TEXTURE TO BE 1.6 UMRA OR BETTER

DE-BURR ALL SHARP EDGES AND HOLES. ITEM MUST BE FREE FROM SCRATCHES, DENTS AND OTHER BLEMISHES.

DIMENSIONS IN MILLIMETRES



15 STURTON STREET, CAMBRIDGE, CB1 2SN  
T: 01223 450090 F: 01223 450061  
www.breathingbuildings.com/products

TITLE: E-STACK: R-SERIES VERSION 6

DRAWING NO:

1332\_9201

REV	DRAWN	DATE	CHKD	DATE
3	CC	25/06/2015		

SCALE 1:15 A2 SHEET 1 OF 2

DO NOT SCALE

IF IN DOUBT, ASK!

REVISIONS

REV.	DESCRIPTION	DATE	APPROVED
-	See Sheet1	-	-

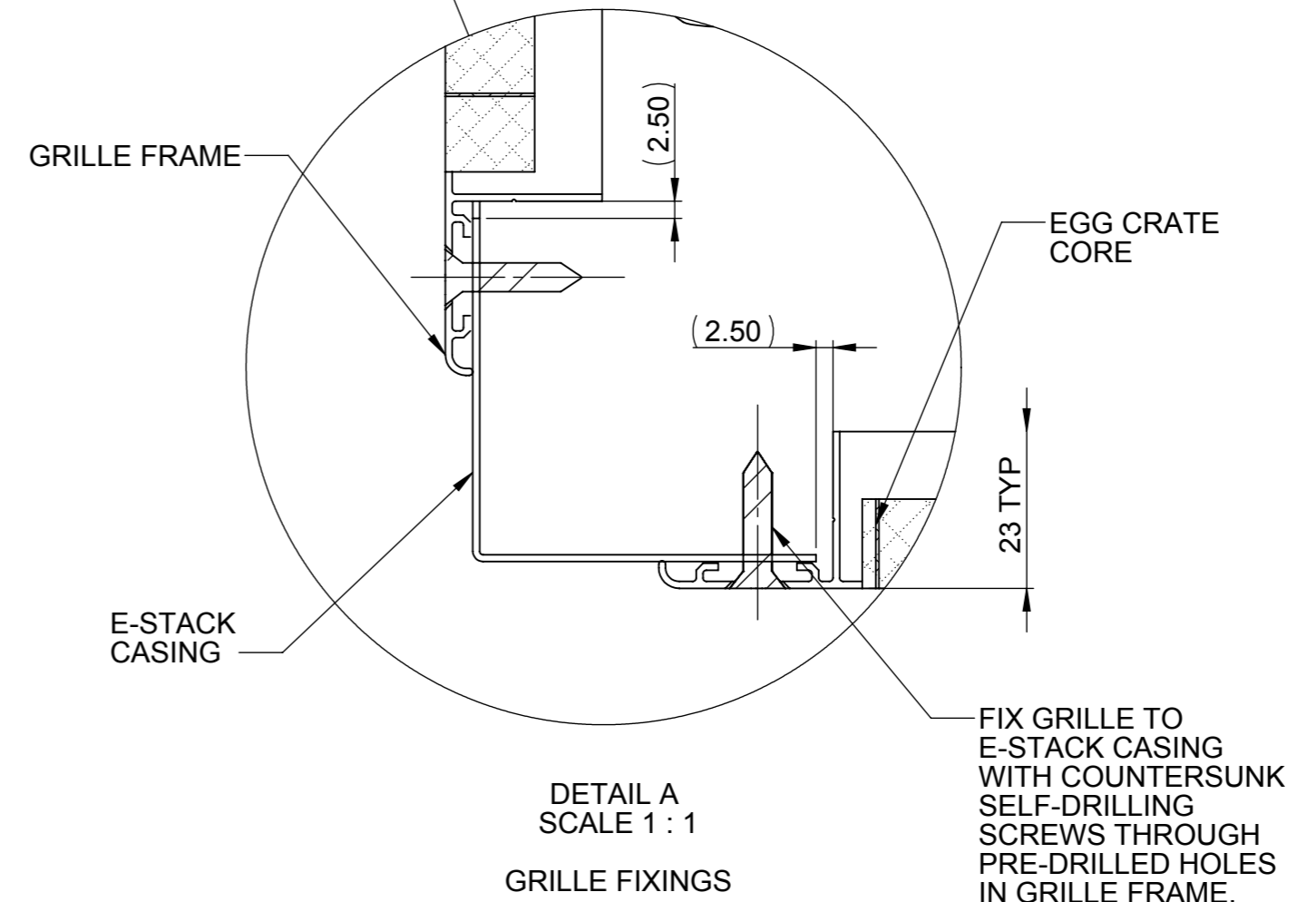
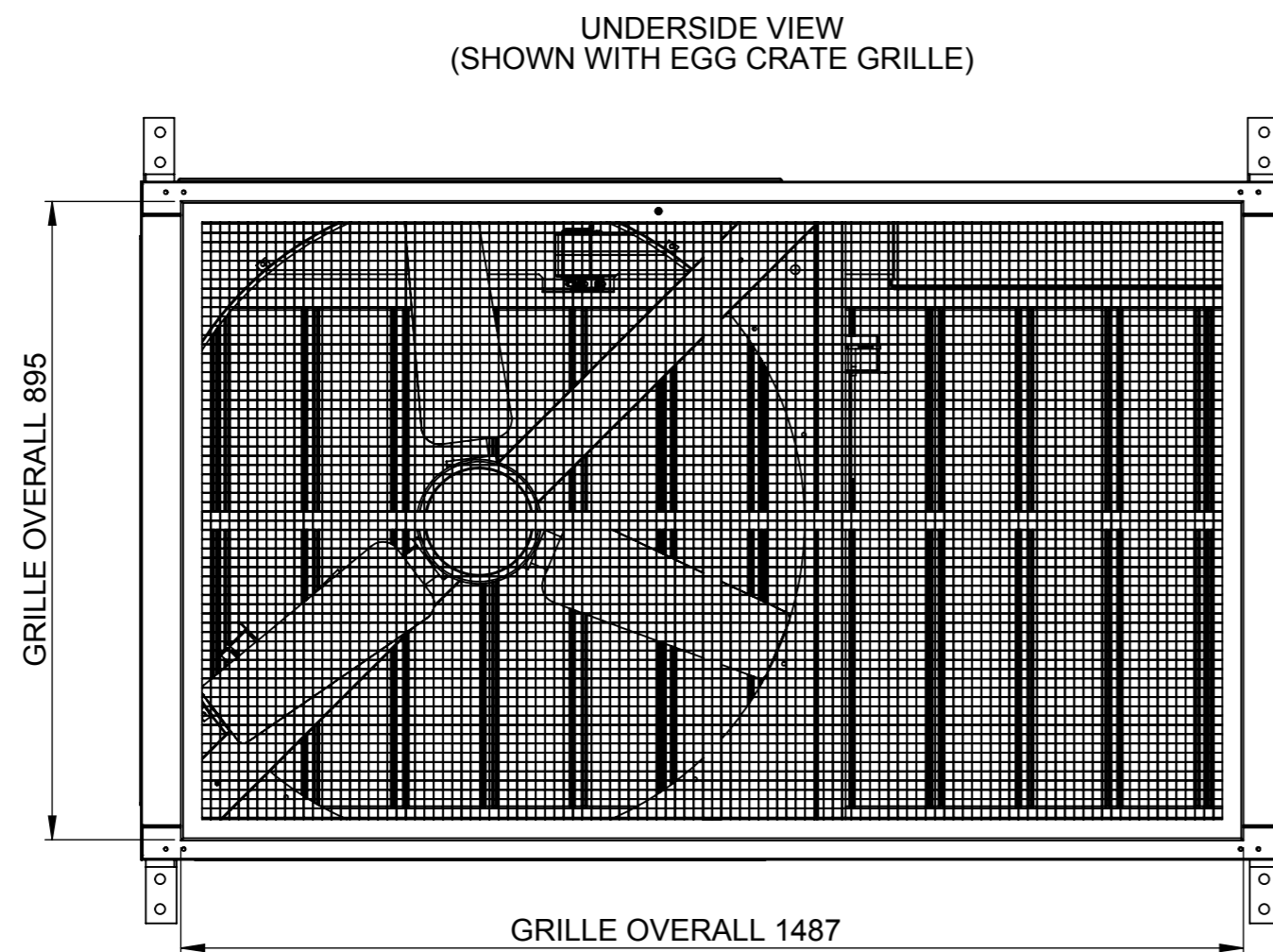
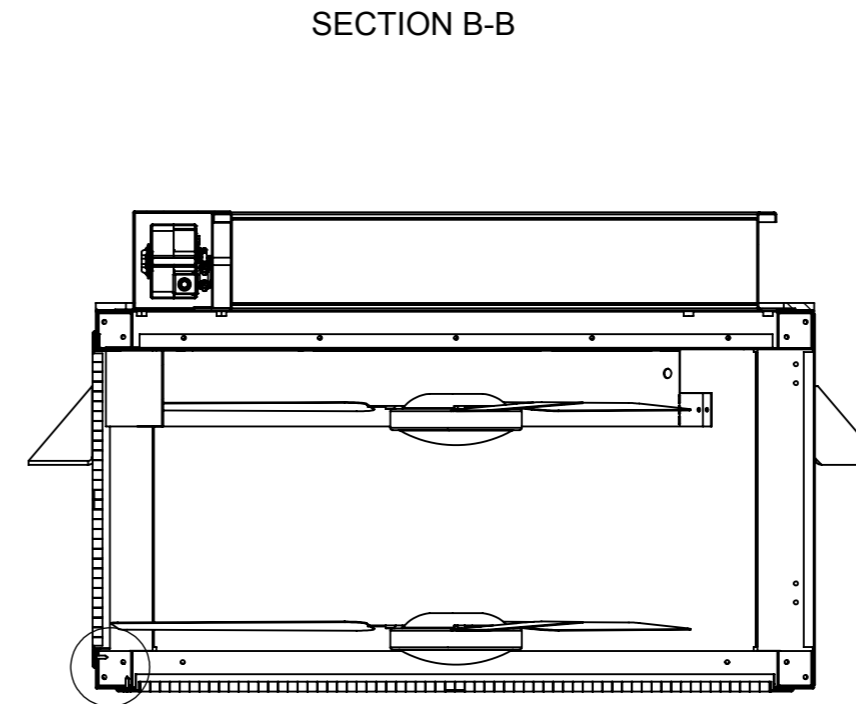
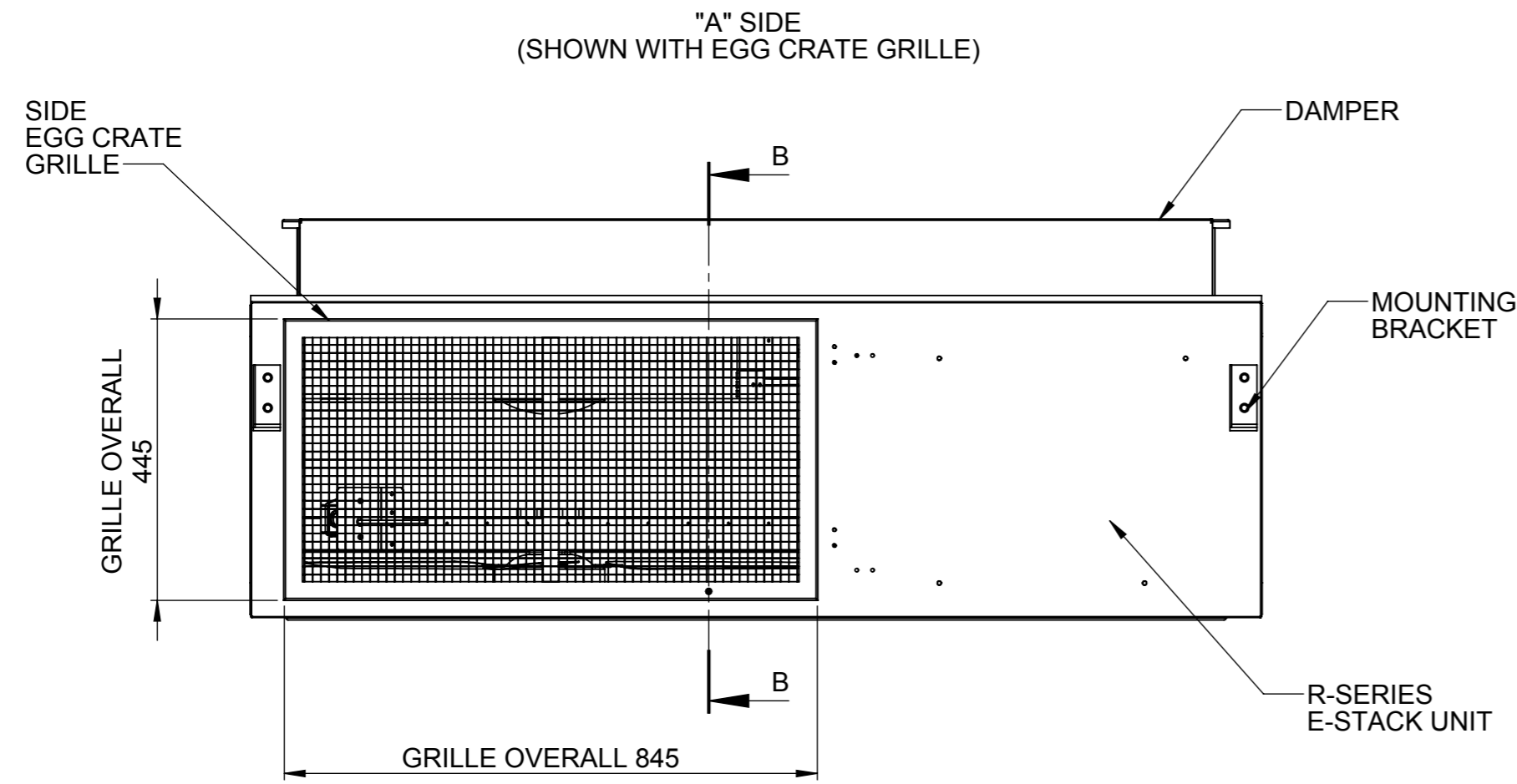

GRILLE OPENING	
POSITION	APERTURE DIMENSION
SIDE	800X400
UNDERSIDE	1442X850

HEIGHT FROM FINISHED FLOOR LEVEL TO UNDERSIDE OF E-STACK	TYPE	OPEN AREA
>2.7M	EGG CRATE	12MM
<2.7M	FINGER GUARD	<8MM

MATERIAL:  
MILD STEEL

FINISH  
GALV. OR POWDER COAT ZINTEC

MASS WITHOUT PACKAGING  
<86KG

TOLERANCES EXCEPT WHERE OTHERWISE STATED  
X : 0.5MM  
X.XX : 0.05MM  
ANGLES : 0.5°

SURFACE TEXTURE TO BE 1.6 UMRA OR BETTER

DE-BURR ALL SHARP EDGES AND HOLES  
ITEM MUST BE FREE FROM SCRATCHES, DENTS AND OTHER BLEMISHES.

DIMENSIONS IN MILLIMETRES



15 STURTON STREET, CAMBRIDGE, CB1 2SN  
T: 01223 450090 F: 01223 450061  
www.breathingbuildings.com/products

TITLE:  
E-STACK: R-SERIES VERSION  
6

DRAWING NO:  
1332\_9201

REV	DRAWN	DATE	CHKD	DATE
3	CC	25/06/2015		



SCALE 1:10 A2 SHEET 2 OF 2