

- Notes:
1. Weight - 168kg
 2. Finish - Galvanized Steel as standard or RAL 9010 available on request at additional cost
 3. Unit shown without grilles. Grilles available on request at additional cost
 4. Unit supplied with fixing brackets

			DEBUR AND BREAK SHARP EDGES AND HOLES. ITEM MUST BE FREE FROM SCRATCHES, DENTS AND OTHER BLEMISHES MATERIAL: Mild Steel FINISH: Mill		TITLE: E-STACK: S1500	
DRAWN CC 29/04/2013	NAME CC	SIGNATURE	DATE 29/04/2013	Tolerances unless otherwise stated x.xx = +/- 0.05 x = +/- 0.5 angles +/- 0.5°	Dimension in mm Third Angle Projection	DWG NO. 1318_9002_03
Q.A.	MFG	APPV'D	CHK'D	Surface texture to be umRa or better Do not scale drawing	SCALE	Revision 3 A3
					SHEET 1 OF 2	

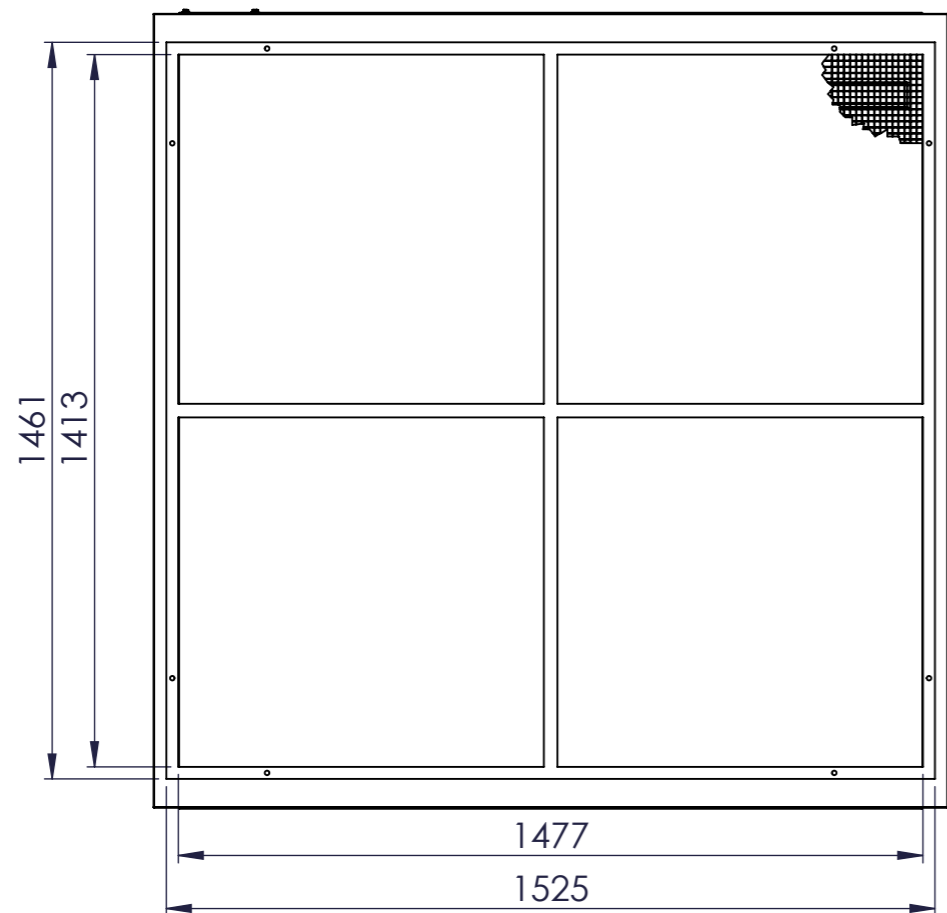
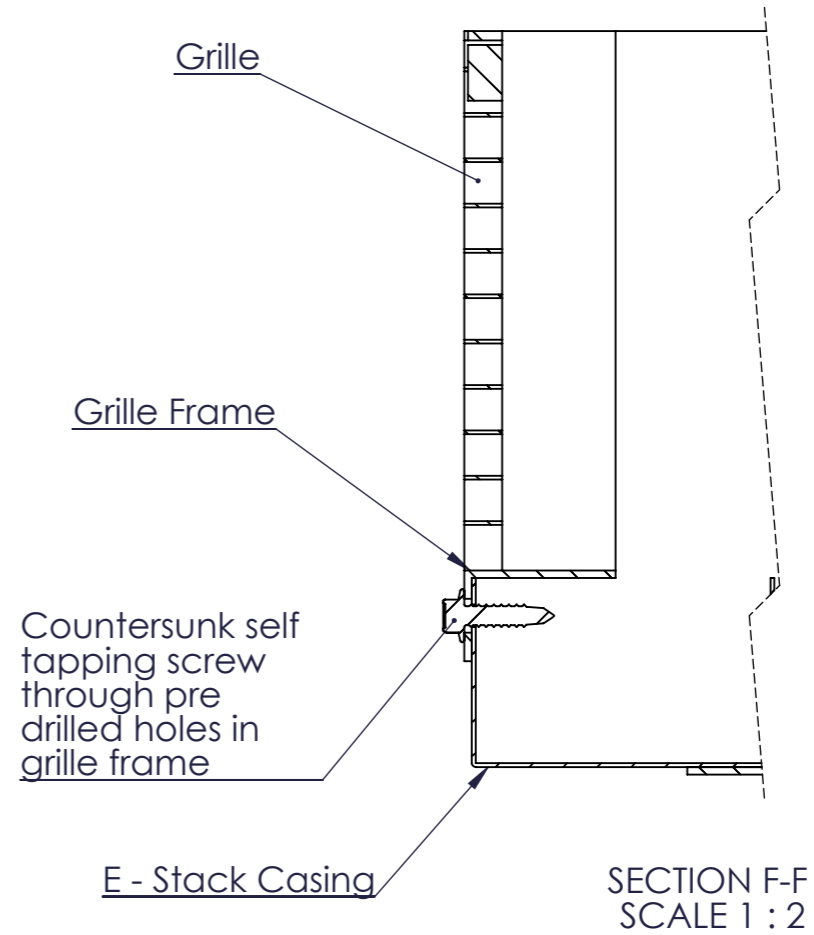
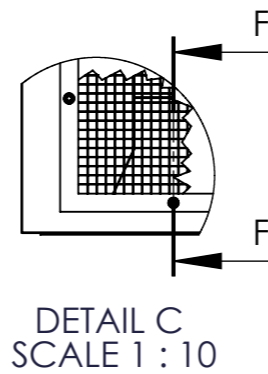
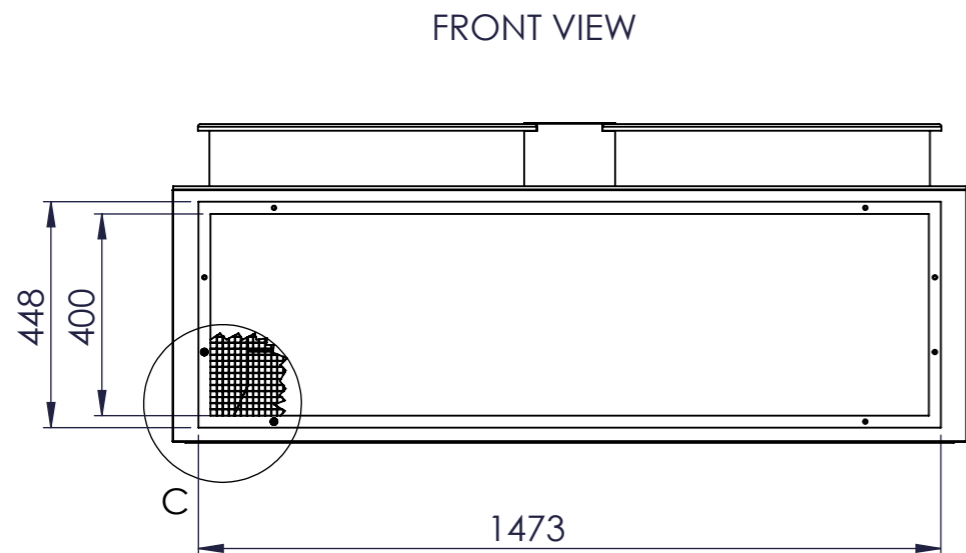

- Notes:
1. Weight - 168kg
 2. Finish - Galvanized Steel as standard or RAL 9010 available on request at additional cost
 3. Unit shown with grilles. Grilles available on request at additional cost
 4. Unit supplied with fixing brackets

		DEBUR AND BREAK SHARP EDGES AND HOLES. ITEM MUST BE FREE FROM SCRATCHES, DENTS AND OTHER BLEMISHES		TITLE: S-1500 with grille	
		MATERIAL: Mild Steel		Revision	
		FINISH: Mill		A3	
DRAWN	NAME CC	SIGNATURE	DATE 29/04/2013	DWG NO. 1318_9002_03	Revision 3
CHK'D					
APPV'D					
MFG				SCALE	SHEET 2 OF 2
Q.A				Surface texture to be umRa or better	Do not scale drawing