

NOTES:-

1. E-STACK SUPPLIED WITH FIXING BRACKETS
2. TYPICAL UNIT WEIGHT. - 59kg
3. FINISH - GALV. BUT AVAILABLE IN RAL COLOURS AT ADDITIONAL COST

				DEBUR AND BREAK SHARP EDGES AND HOLES. ITEM MUST BE FREE FROM SCRATCHES, DENTS AND OTHER BLEMISHES MATERIAL: Mild steel		TITLE: E-STACK: F500 VERSION 1		
				FINISH: Galv.		DWG NO. 1202_9002_01		
DRAWN CC	NAME CC	SIGNATURE	DATE 22/04/2013	Tolerances unless otherwise stated x.xx = +/- 0.05 x = +/- 0.5 angles +/- 0.5°	Dimension in mm Third Angle Projection	Revision 1		
CHECKED	APPROVED	MFG	Q.A	Surface texture to be umRa or better	Do not scale drawing	A3	SCALE 1:15	SHEET 1 OF 3

TOP

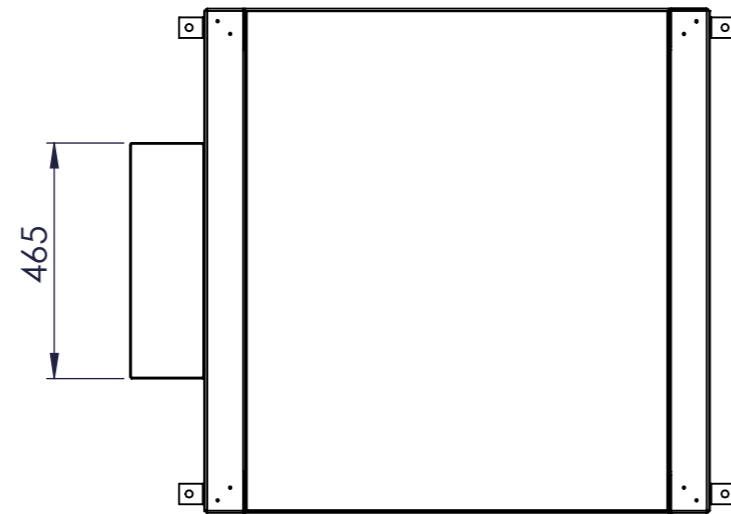

EXTERNAL CONTROL BOX

ISOMETRIC VIEW

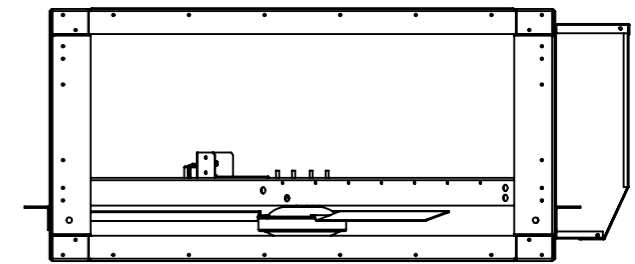
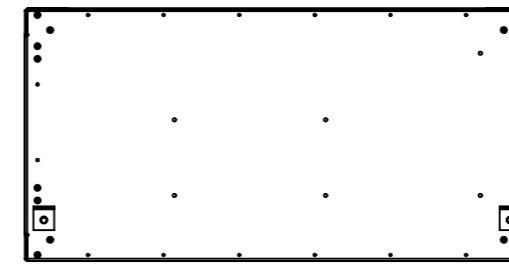
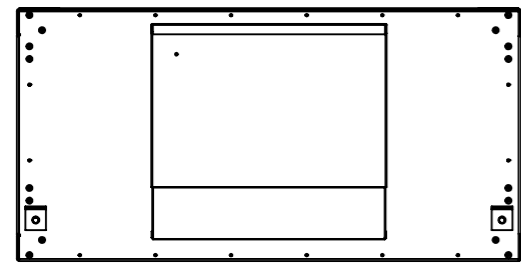
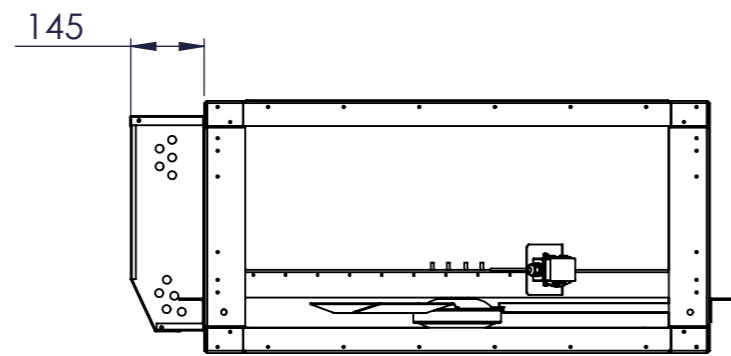
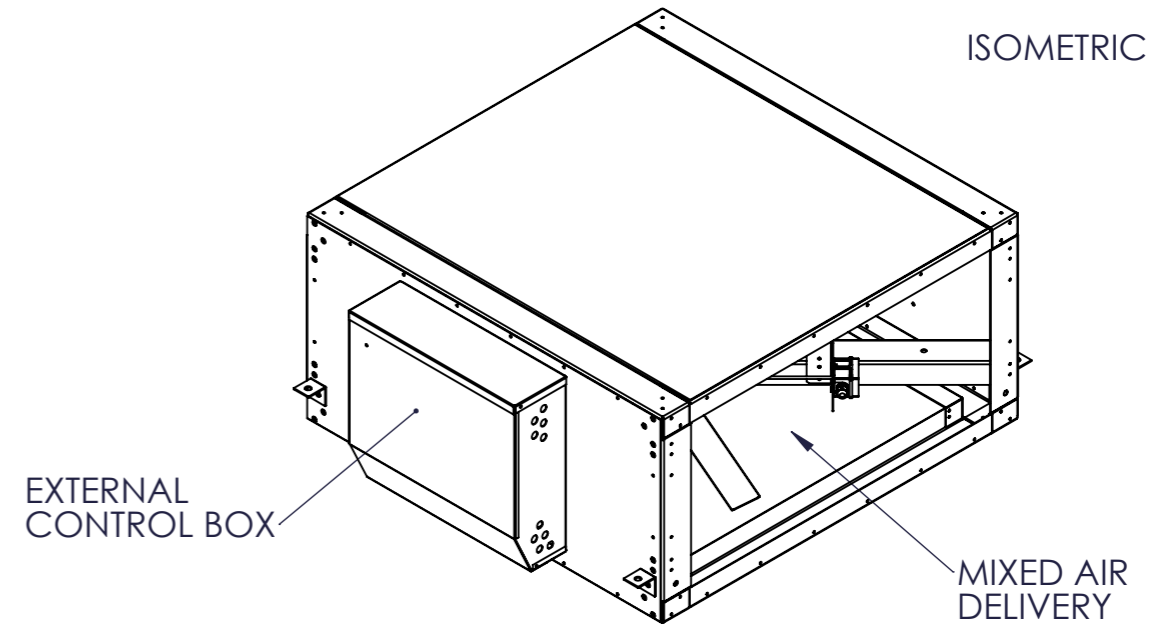

LEFT

FRONT

RIGHT

BACK

EXTERNAL CONTROL BOX

FIXING BRACKET

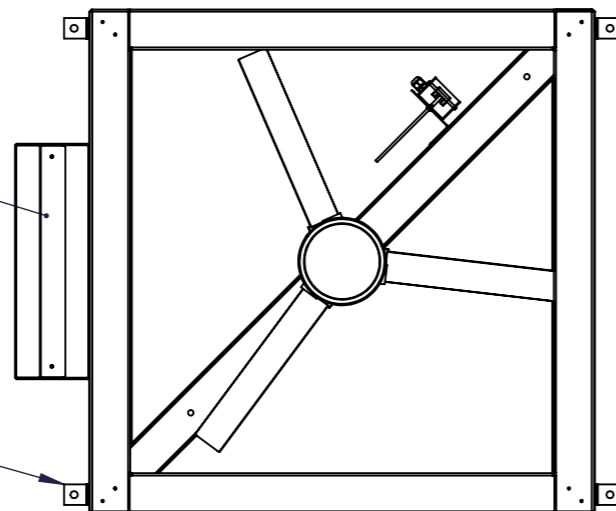

BOTTOM

NOTES:-

1. E-STACK SUPPLIED WITH FIXING BRACKETS
2. TYPICAL UNIT WEIGHT. - 59kg
3. FINISH - GALV. BUT AVAILABLE IN RAL COLOURS AT ADDITIONAL COST

				DEBUR AND BREAK SHARP EDGES AND HOLES. ITEM MUST BE FREE FROM SCRATCHES, DENTS AND OTHER BLEMMISHES MATERIAL: Mild steel		TITLE: E-STACK: F500 VERSION 1	
				FINISH: Galv.		DWG NO. 1202_9002_01	
DRAWN CC	NAME CC	SIGNATURE	DATE 22/04/2013	Tolerances unless otherwise stated x.xx = +/- 0.05 x = +/- 0.5 angles +/- 0.5°	Dimension in mm Third Angle Projection	SCALE 1:15	SHEET 2 OF 3
CHECKED	APPROVED	MFG	Q.A	Surface texture to be umRa or better	Do not scale drawing	A3	1

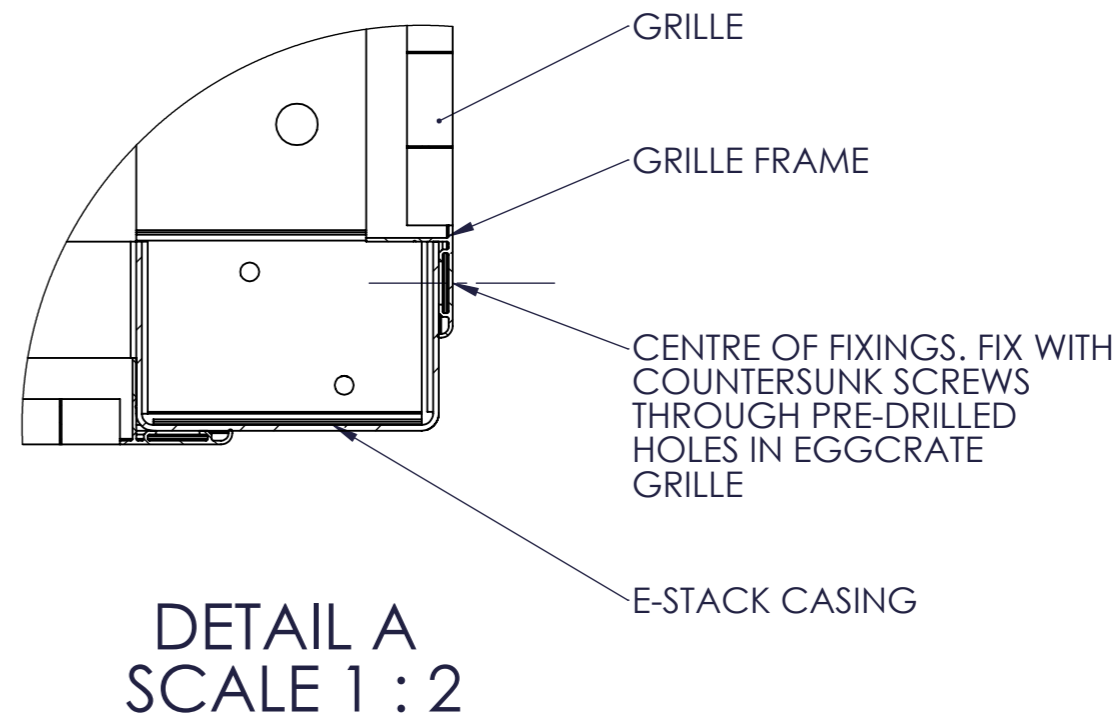
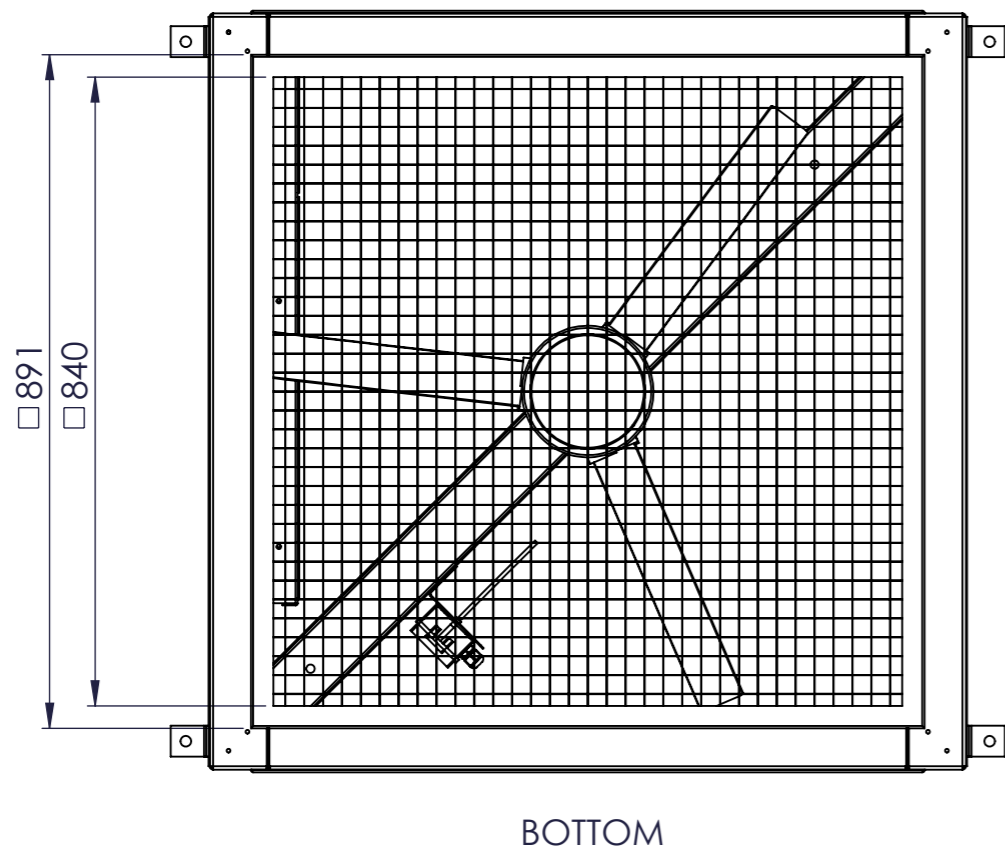
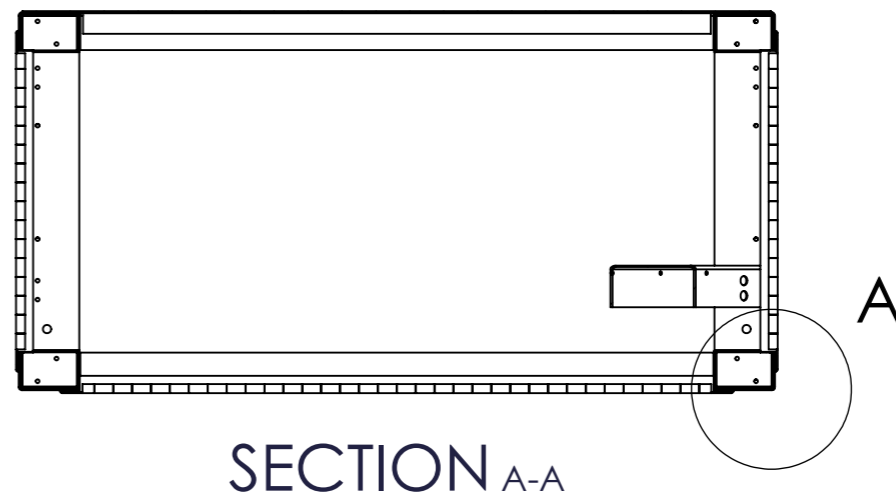
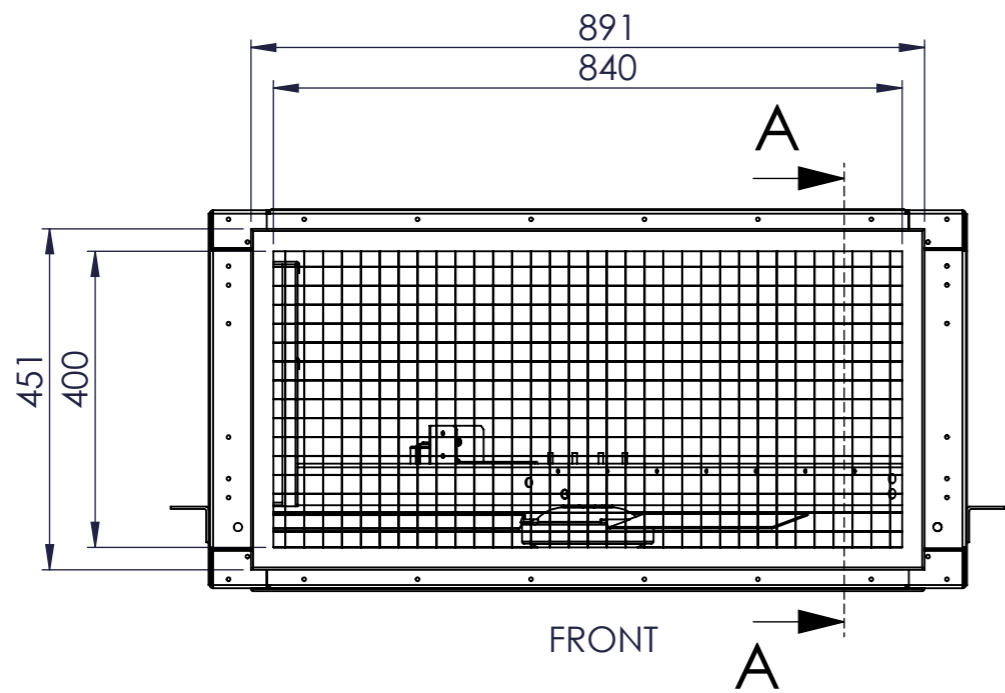

NOTES:-

1. E-STACK SUPPLIED WITH FIXING BRACKETS
2. TYPICAL UNIT WEIGHT. - 59kg
3. FINISH - GALV. BUT AVAILABLE IN RAL COLOURS AT ADDITIONAL COST

				DEBUR AND BREAK SHARP EDGES AND HOLES. ITEM MUST BE FREE FROM SCRATCHES, DENTS AND OTHER BLEMMISHES MATERIAL: Mild steel		TITLE: E-STACK: F500 VERSION 1	
				FINISH: Galv.		DWG NO. 1202_9002_01	
DRAWN CC	NAME CC	SIGNATURE	DATE 22/04/2013	Tolerances unless otherwise stated x.xx = +/- 0.05 x = +/- 0.5 angles +/- 0.5°	Dimension in mm Third Angle Projection	Revision 1	
CHECKED	APPROVED	MFG	Q.A	Surface texture to be umRa or better	Do not scale drawing	A3	SCALE 1:10 SHEET 3 OF 3