

DO NOT SCALE

IF IN DOUBT, ASK!

REVISIONS

REV.	DESCRIPTION	DATE	DRAWN
1	FIRST ISSUE	27/08/2014	CC

Notes:

- Unit finished in galv. as standard. RAL colours available on request at additional cost.
- Mixed air delivery outlet through "B" side as standard.
- Unit supplied with 4 no. mounting brackets as shown as standard.
- Unit can be hung from M10 studding through fixing brackets.
- Unit shown without grilles. Grilles available on request at additional cost.
- If unit is positioned less than 2.7m above ground, finger guard grilles must be used.
- Divider to be aligned with similar divider in shaft and roof terminal during installation to create two air pathways.
- Weight R-Series (without pallet and grilles) approx. 86kg

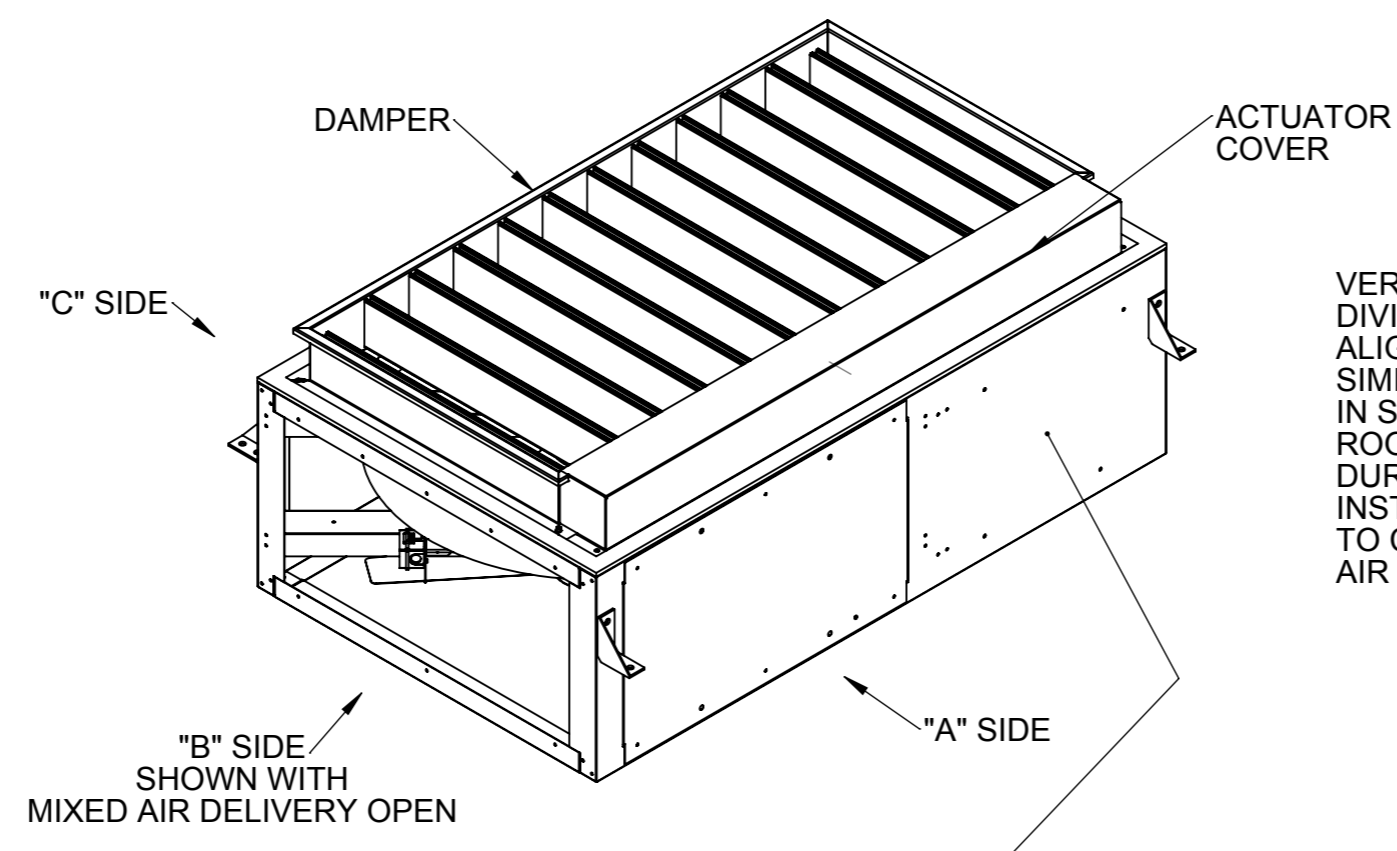
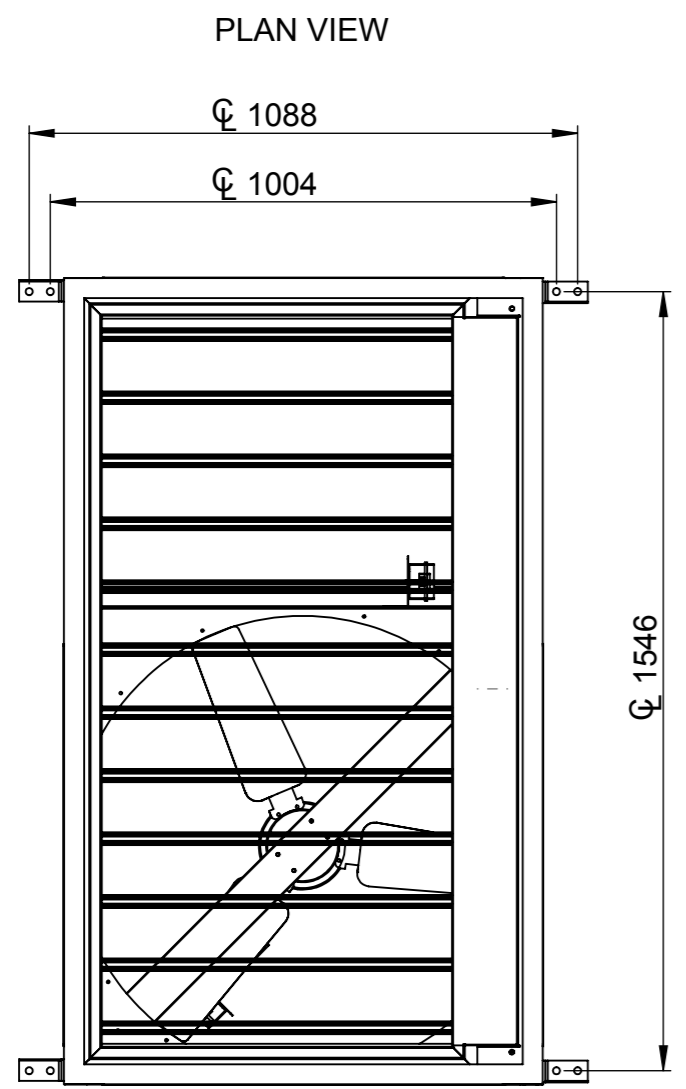

VERTICAL DIVIDER TO BE ALIGNED WITH SIMILAR DIVIDER IN SHAFT AND ROOF TERMINAL DURING INSTALLATION TO CREATE TWO AIR PATHWAYS

R-SERIES SHOWN IN-CONTEXT OF INSTALLATION WITH GRP MUSHROOM ROOF TERMINATION TO SHOW VERTICAL DIVIDER.

REFER TO INSTALLATION DRAWINGS FOR DIMENSIONS AND INSTALL DETAIL.

Up-stand must be level

OPPOSING DAMPER BLADES FOR MODULATING CONTROL

CONTROL BOX LOCATION DO NOT DRILL THROUGH THIS AREA - ACCESS FOR CABLES TO LEFT SIDE OF SPACE ENVELOPE (500X500)

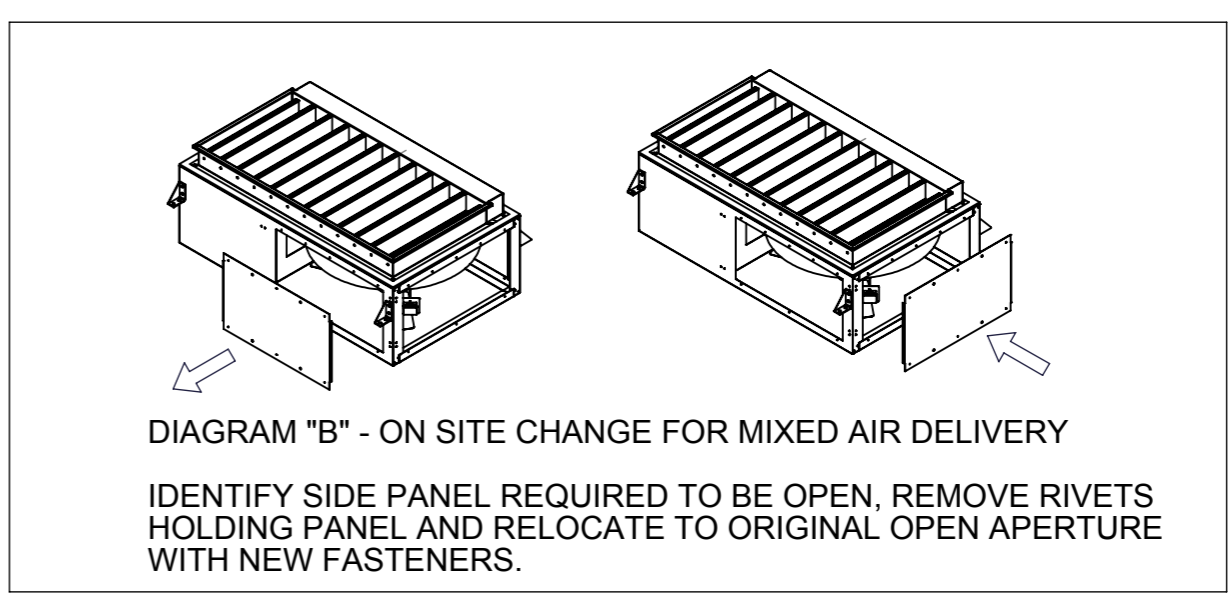
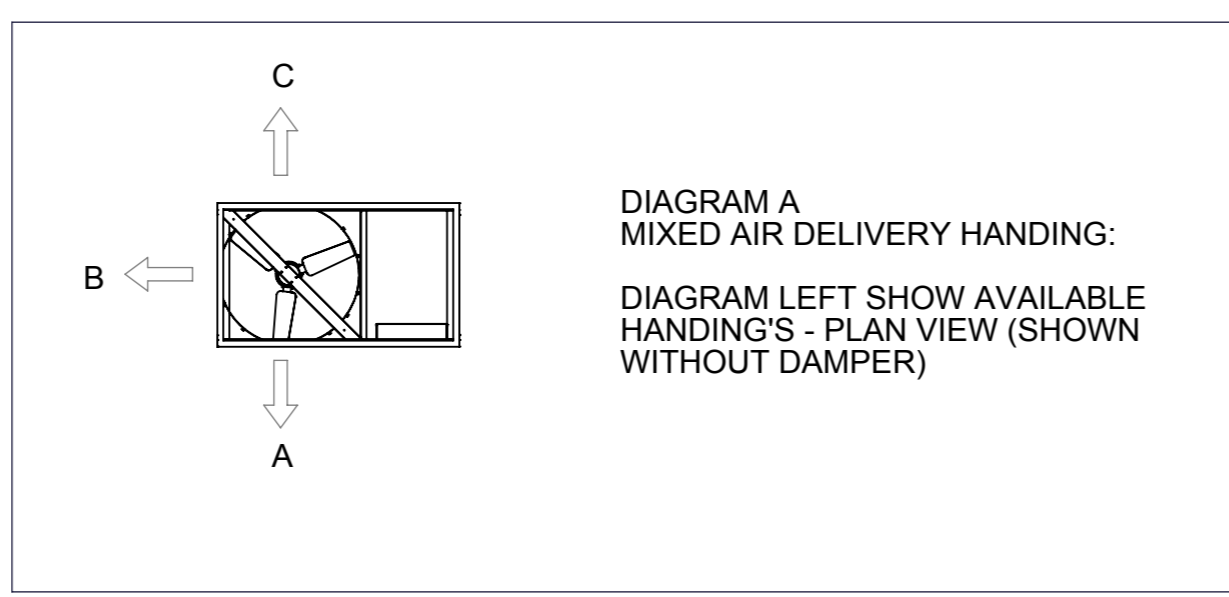
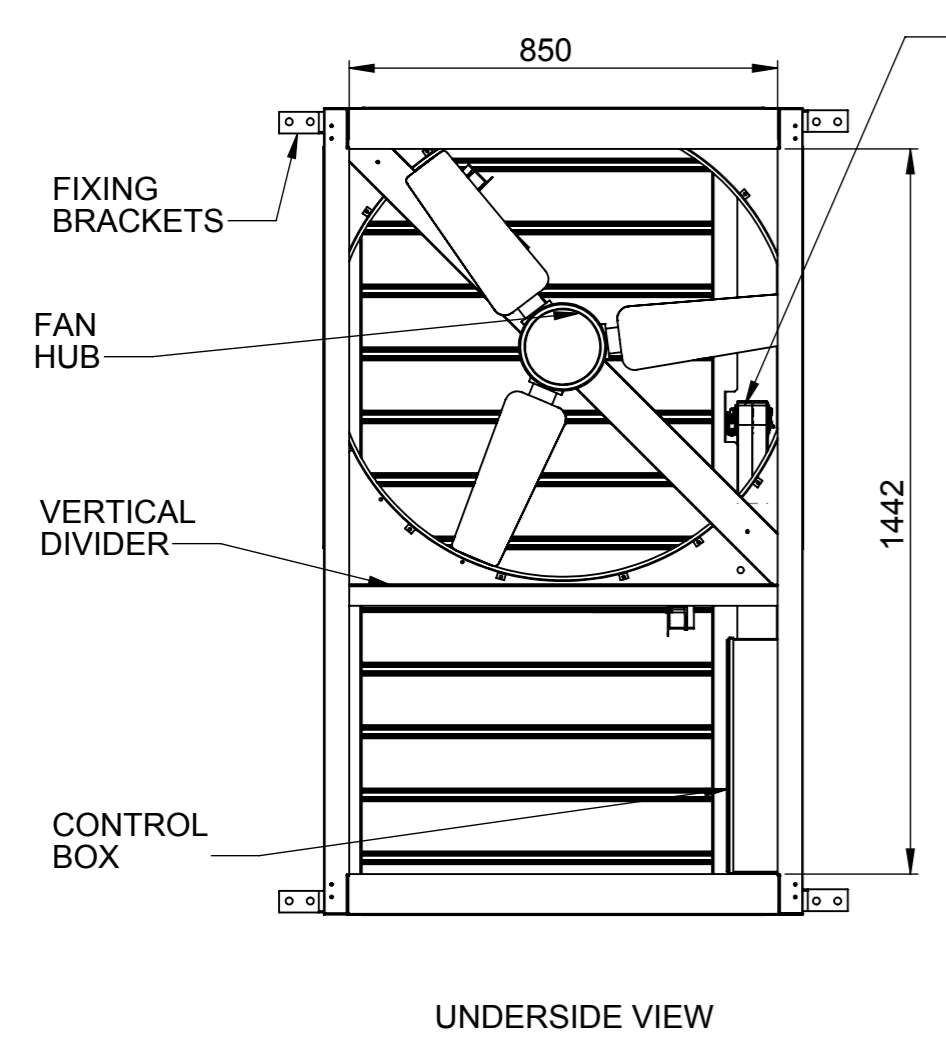
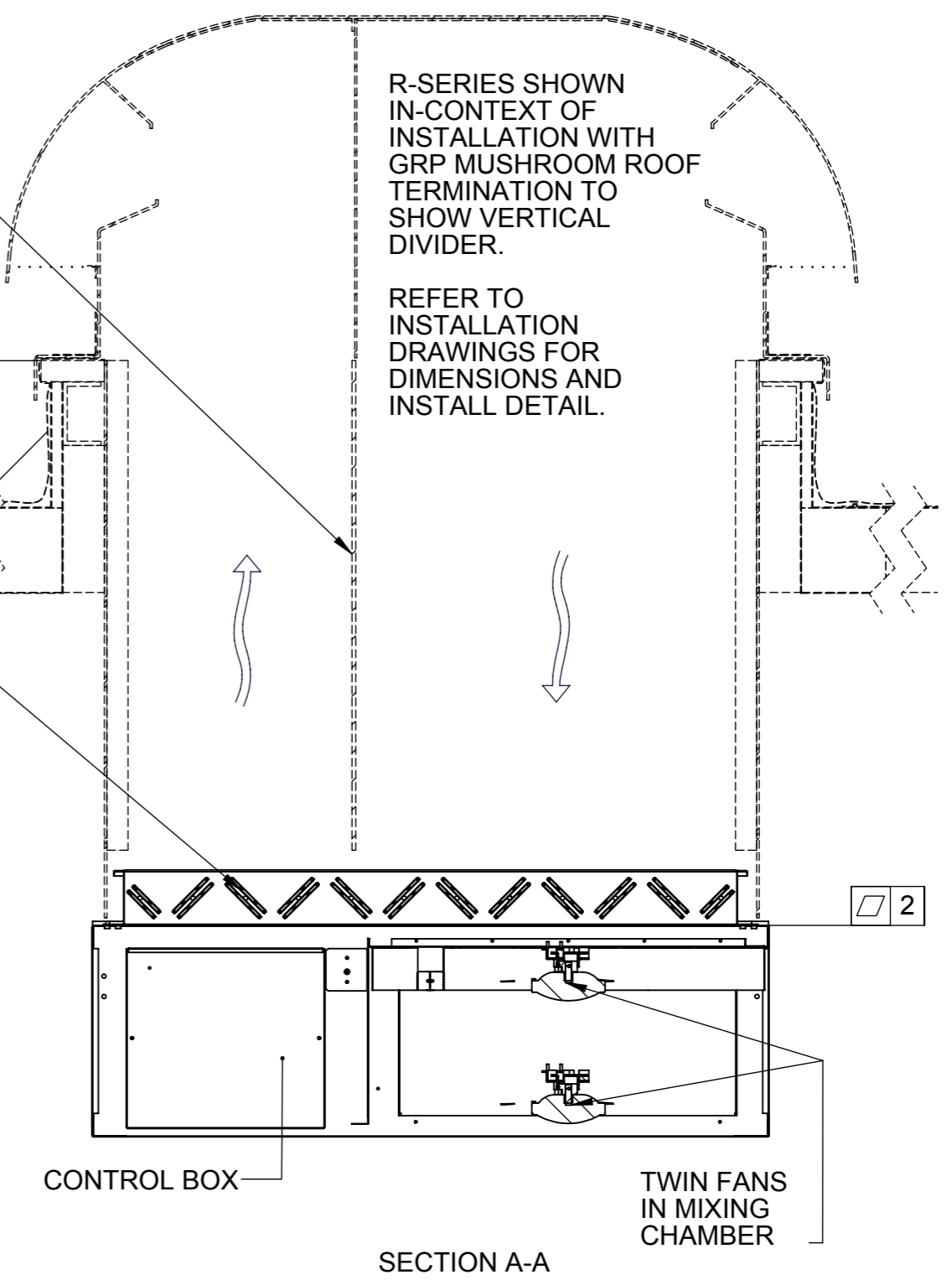
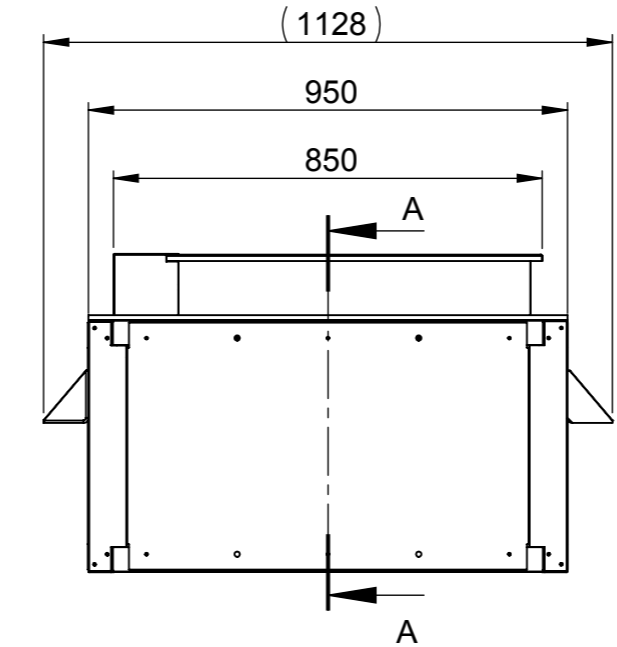
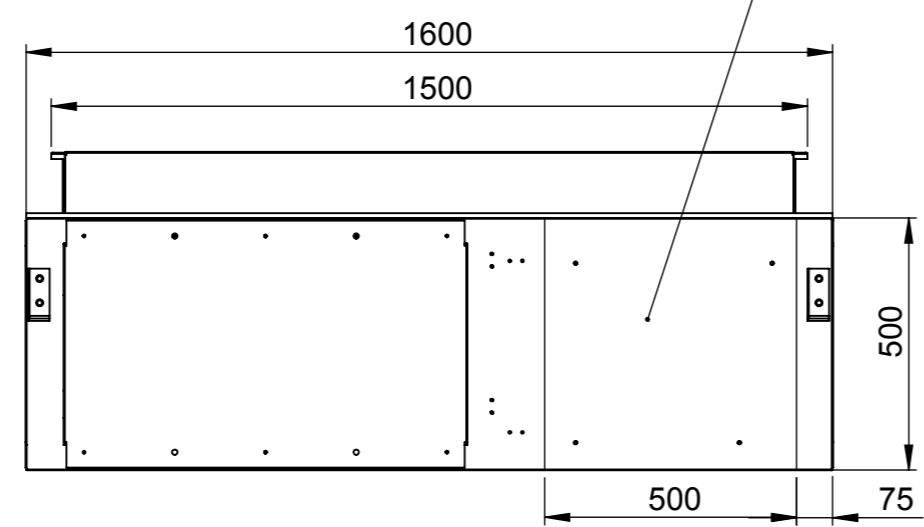
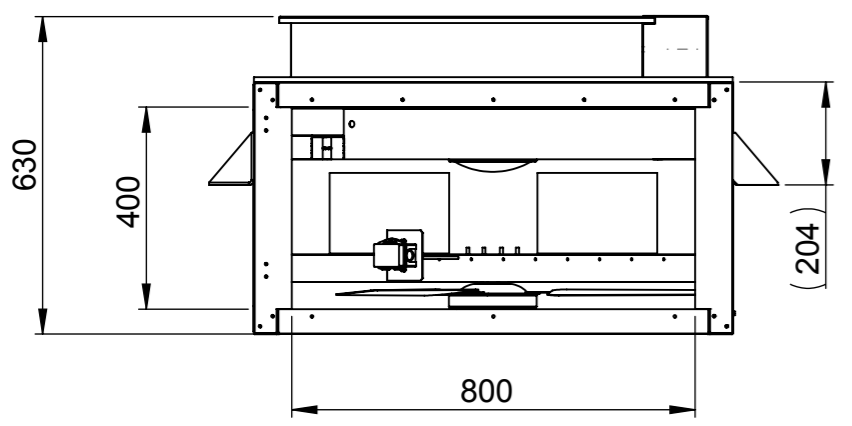

TOLERANCES EXCEPT WHERE OTHERWISE STATED

X	±	0.5MM
X.XX	±	0.05MM
ANGLES	±	0.5°

SURFACE TEXTURE TO BE 1.6 UMRA OR BETTER

DE-BURR ALL SHARP EDGES AND HOLES ITEM MUST BE FREE FROM SCRATCHES, DENTS AND OTHER BLEMISHES.

DIMENSIONS IN MILLIMETRES



TITLE:  
 E-STACK: R-SERIES VERSION 6 WITH LOW 'U' VALUE DAMPER

DRAWING NO:  
 1332\_9001\_01

MATERIAL: MILD STEEL

FINISH:  
 GALV. OR POWDER COAT ZINTEC

REV	DRAWN	DATE	CHK'D	DATE
1	CC	27/08/2014	DP	27/08/2014

SCALE 1:15 A3 SHEET 1 OF 2

DO NOT SCALE

IF IN DOUBT, ASK!

REVISIONS

REV.	DESCRIPTION	DATE	APPROVED
-	See Sheet1	-	-

Notes:

- Unit finished in galv. mild steel as standard. RAL colours available on request at additional cost.
- Mixed air delivery outlet through "B" side as standard.
- Unit supplied with 4 no. mounting brackets as shown as standard. Unit can be hung from M10 studding through fixing brackets.
- Unit shown with grilles. Grilles available on request at additional cost.
- If unit is positioned less than 2.7m above ground, finger guard grilles must be used.
- Divider to be aligned with similar divider in shaft and roof terminal during installation to create two air pathways.
- Weight R-Series (without pallet and grilles) approx. 86kg

TOLERANCES EXCEPT WHERE OTHERWISE STATED

X	±	0.5MM
X.XX	±	0.05MM
ANGLES	±	0.5°

SURFACE TEXTURE TO BE 1.6 UMRA OR BETTER

DE-BURR ALL SHARP EDGES AND HOLES  
ITEM MUST BE FREE FROM SCRATCHES, DENTS AND OTHER BLEMISHES.

DIMENSIONS IN MILLIMETRES



15 STURTON STREET, CAMBRIDGE, CB1 2SN  
T: 01223 450080 F: 01223 450081  
WWW.BREATHINGBUILDINGS.COM

TITLE:  
E-STACK: R-SERIES VERSION 6 WITH LOW 'U' VALUE DAMPER

DRAWING NO:  
1332\_9001\_01

MATERIAL: MILD STEEL

FINISH:  
GALV. OR POWDER COAT ZINTEC

REV	DRAWN	DATE	CHK'D	DATE
1	CC	27/08/2014	DP	27/08/2014

SCALE 1:10 A3 SHEET 2 OF 2

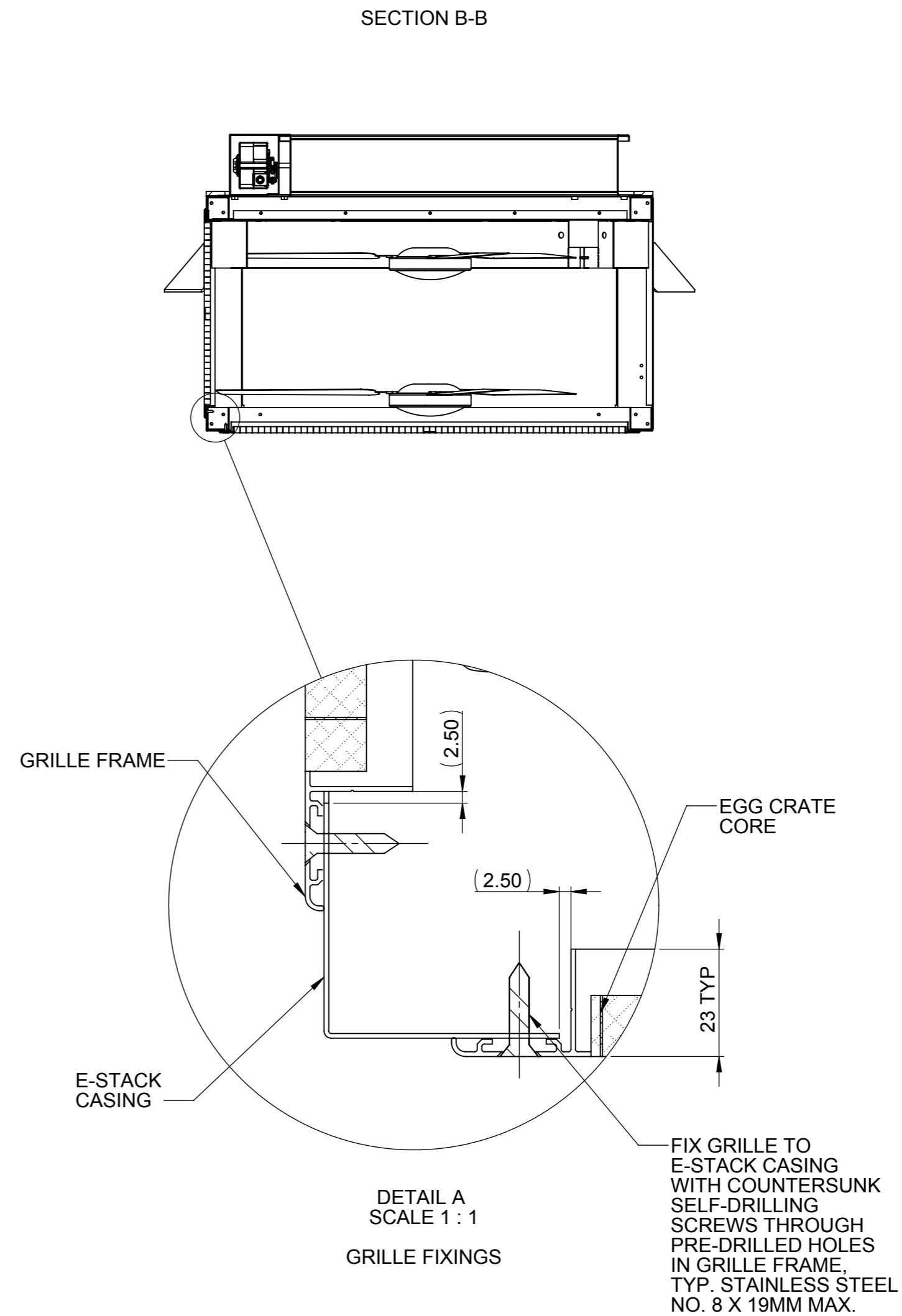
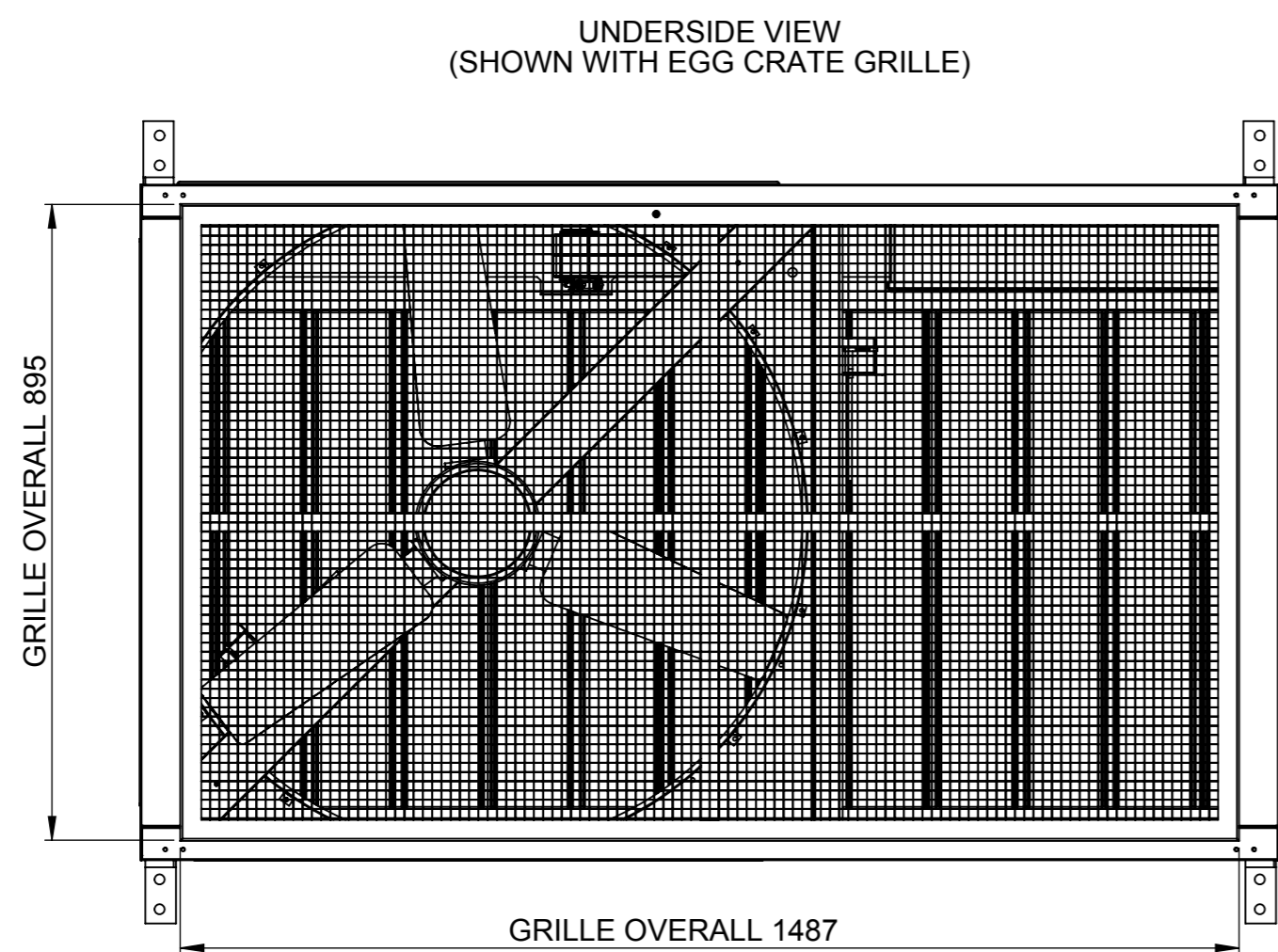
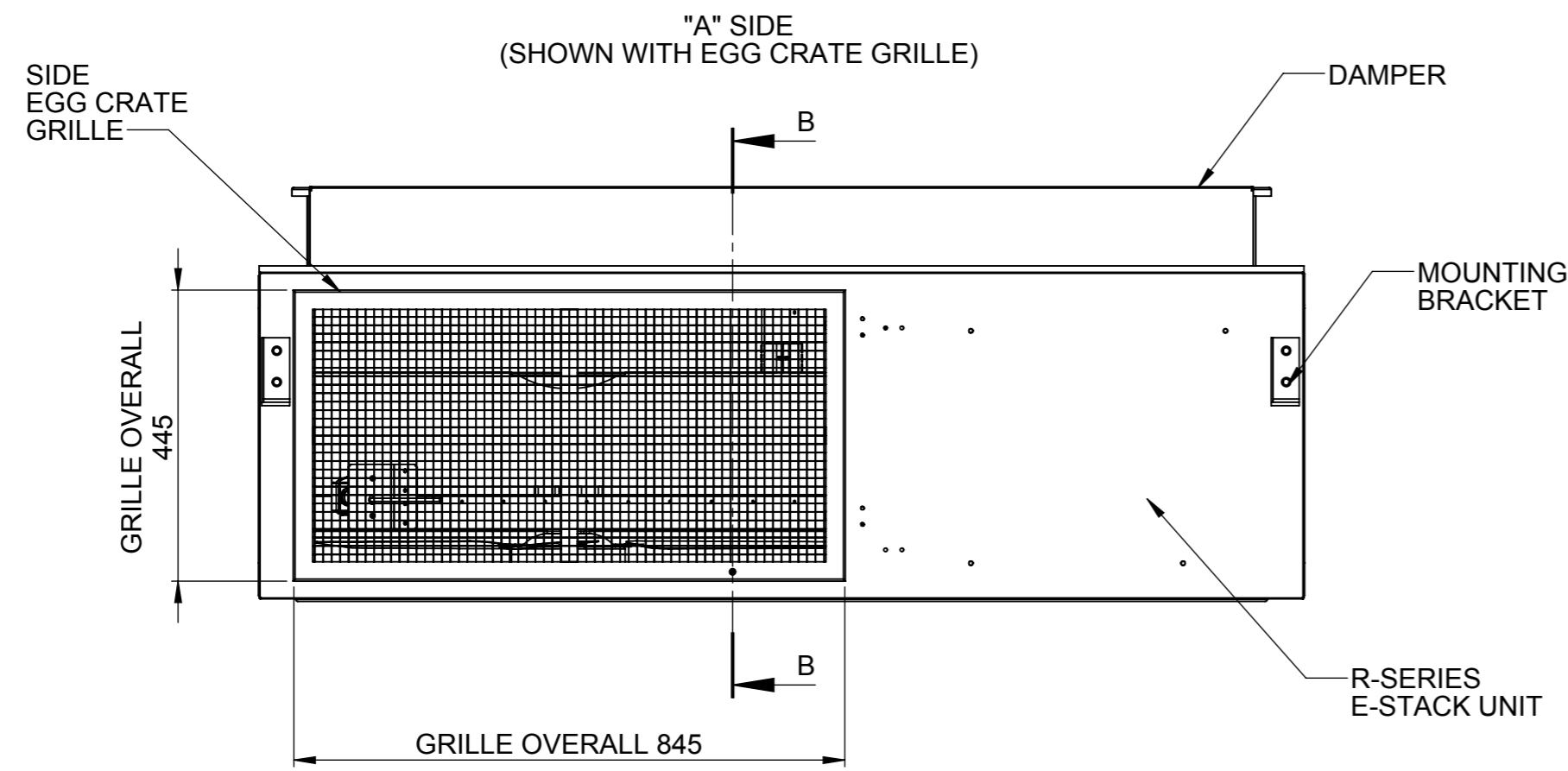

GRILLE OPENING	
POSITION	APERTURE DIMENSION
SIDE	800X400
UNDERSIDE	1442X850

HEIGHT FROM FINISHED FLOOR LEVEL TO UNDERSIDE OF E-STACK	TYPE	OPEN AREA
>2.7M	EGG CRATE	12MM
<2.7M	FINGER GUARD	<8MM