

**DO NOT SCALE**

**IF IN DOUBT, ASK!**

REVISIONS

REV.	DESCRIPTION	DATE	DRAWN
1	FIRST ISSUE	05/03/2014	CC
2	UPDATE	05/03/2014	CC
3	UPDATE	25/03/2014	CC
4	UPDATE	27/08/2014	CC
5	ADD NOTE	27/07/2016	CC

NOTES:

1. TYPICAL WEIGHT APPROX. 150KG
2. DEFAULT COLOUR RAL 7035 GREY BUT AVAILABLE IN OTHER COLOURS AT ADDITIONAL COST
3. BUILDERS TO CHECK STRUCTURAL OPENING AND REPORT IF NOT WITHIN TOLERANCES
4. MUSHROOM ROOF TERMINAL UNITS MUST BE OFF-LOADED FROM DELIVERY WITH THE PROVIDED "SOFT EYED 6M E.W.L" WEBBING SLINGS S.W.L 1000KG
5. REMOVE 4NO. 300X120X45MM TIMBER FIXED TO BASE OF ROOF TERMINAL PRIOR TO INSTALLATION

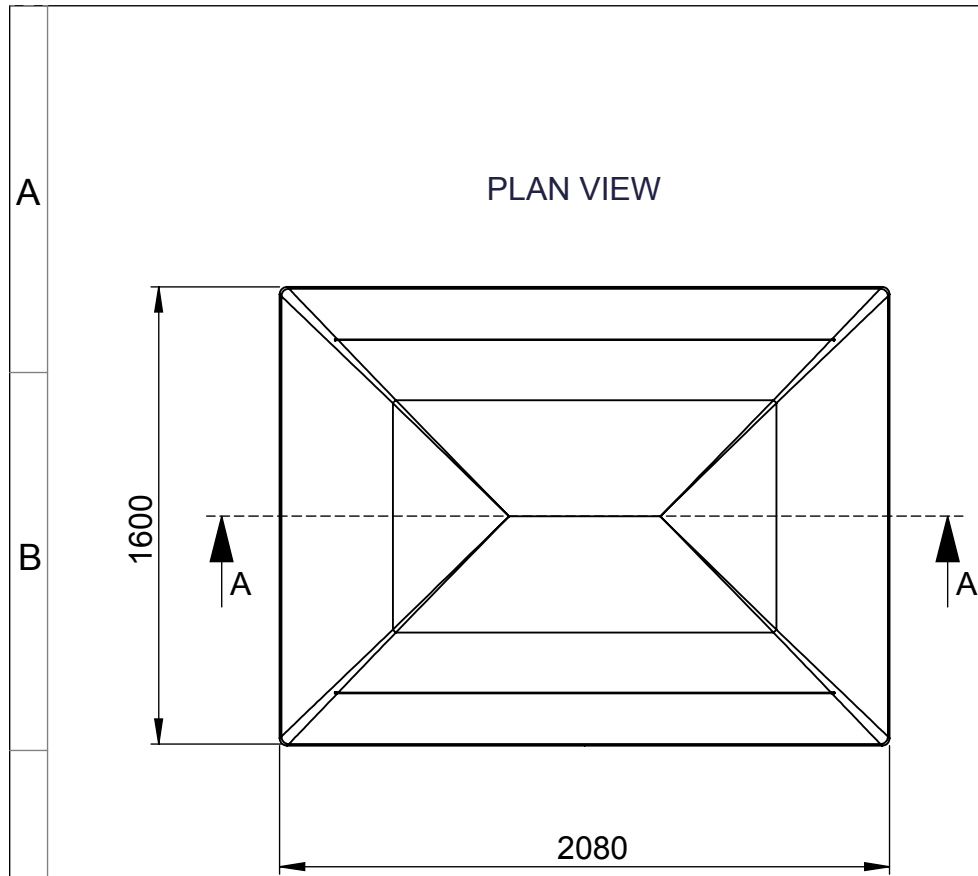

TYPICAL LIFTING METHOD

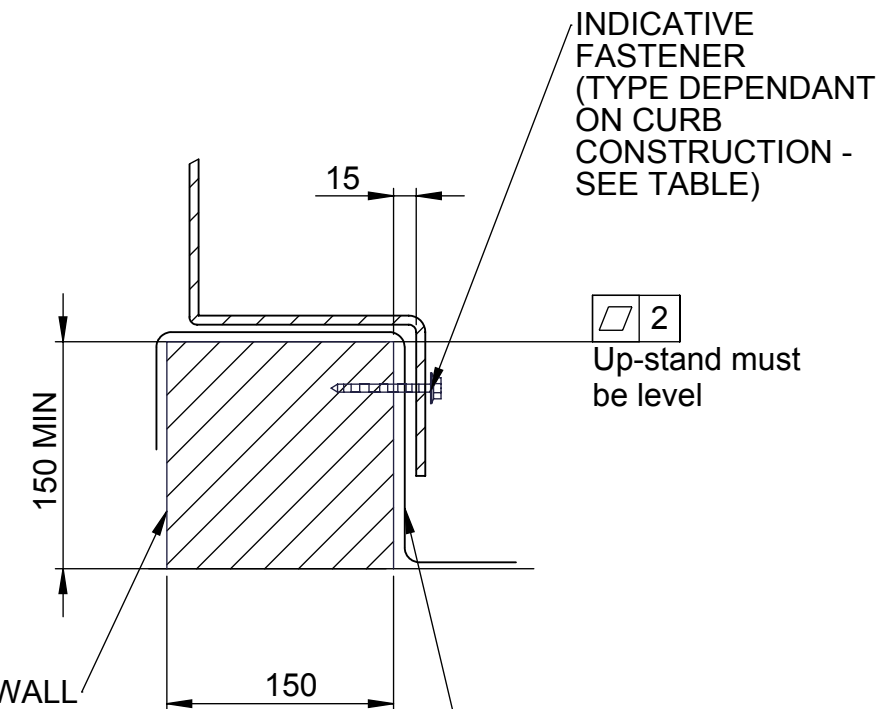
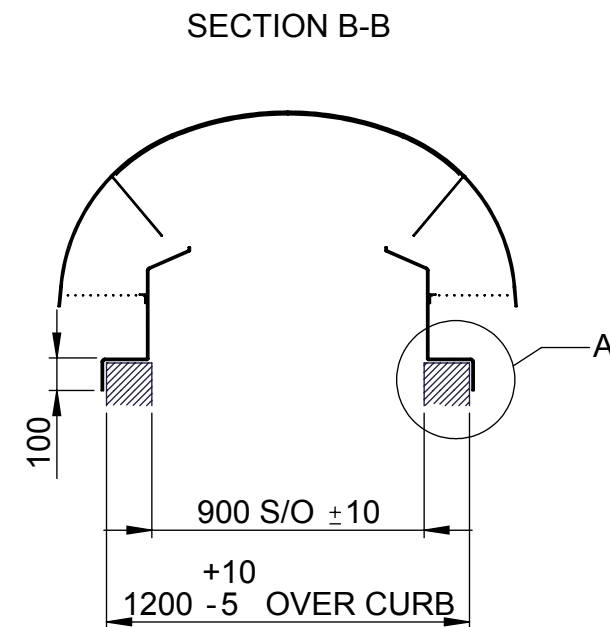
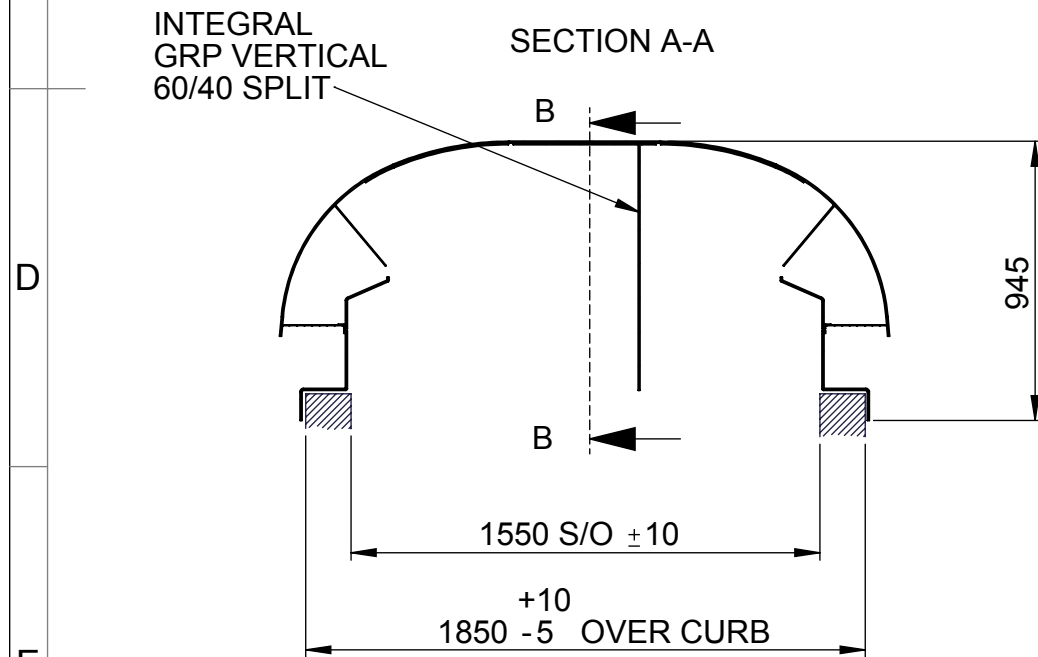
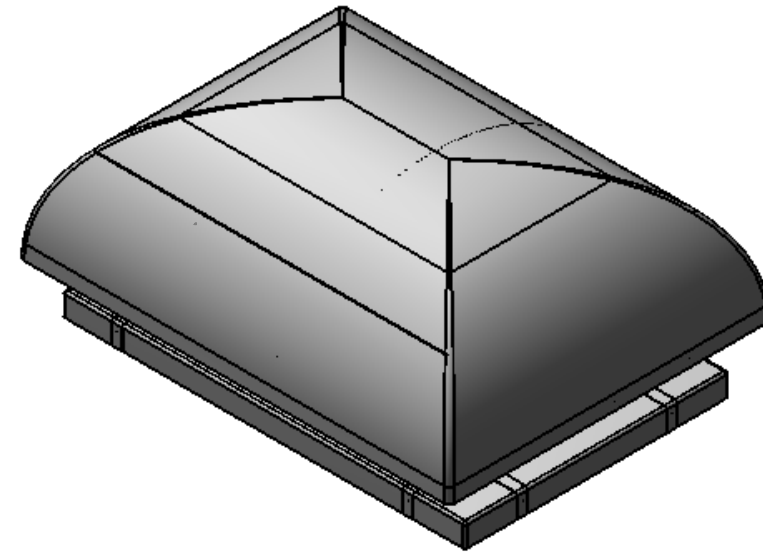
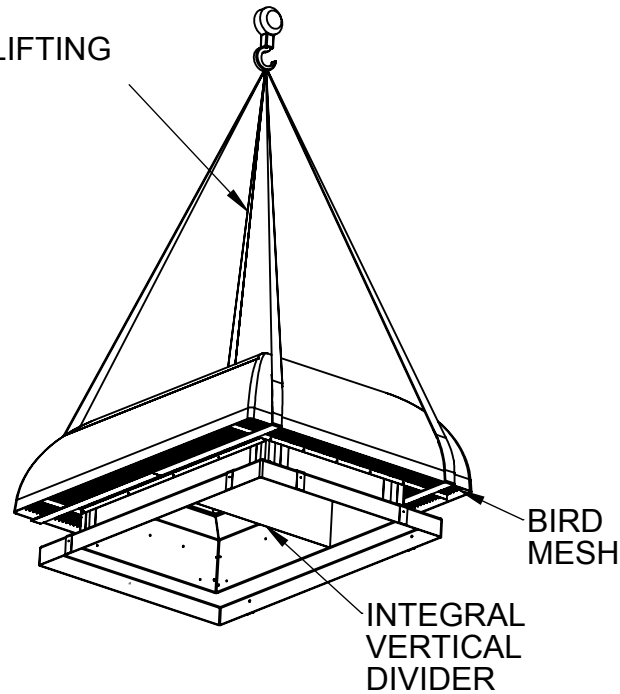

TOLERANCES EXCEPT WHERE OTHERWISE STATED

X	±	0.5MM
X.XX	±	0.05MM
ANGLES	±	0.5°

SURFACE TEXTURE TO BE 1.6 UMRA OR BETTER

DE-BURR ALL SHARP EDGES AND HOLES. ITEM MUST BE FREE FROM SCRATCHES, DENTS AND OTHER BLEMISHES.

DIMENSIONS IN MILLIMETRES



15 STURTON STREET, CAMBRIDGE, CB1 2SN  
T: 01223 450060 F: 01223 450061  
WWW.BREATHINGBUILDINGS.COM

TITLE:

DRAWING NO:

1310\_9001\_05

MATERIAL: GRP

FINISH: GELL COAT RAL 7035 (STD)

REV	DRAWN	DATE	CHK'D	DATE
5	CC	27/07/2016		

SCALE 1:25 A3 SHEET 1 OF 1

UP-STAND MATERIAL	FIXING
CONCRETE	M6 STAINLESS STEEL RESIN ANCHOR
TIMBER	STAINLESS STEEL M6 BOLT OR 5MM DIA SCREW
STEEL	5MM DIA STAINLESS STEEL SELF-TAPPING SCREW
MASONRY	NOT RECOMMENDED